

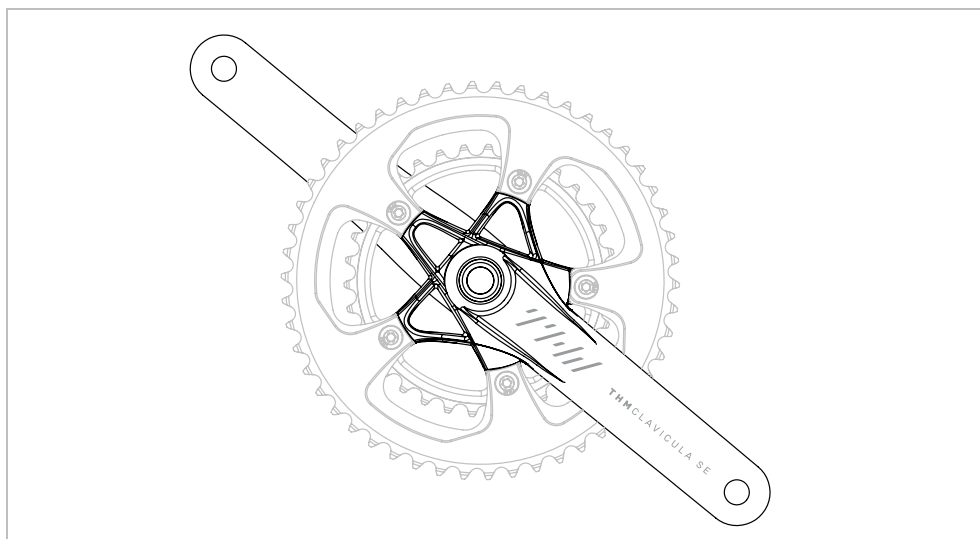

INSTRUCTION BOOK



THMCLAVICULA SE



 Don't forget that your THM component is a lightweight carbon design.

Be aware of this when carrying out assembly and maintenance work and when handling the component. Proceed with utmost care!

CONTENT	4
INTRODUCTION	5
Preface.....	5
SAFETY.....	6
Intended use	6
Fundamental safety precautions.....	6
Assembly & Maintenance	7
On the road.....	8
Transport & Storage.....	8
SPECIFICATIONS	9
Scope of delivery	9
Size.....	10
THM Bottom Bracket	11
Tightening Torques	14
Application area.....	14
INSTALL	15
General Information	15
Preparing the Frame.....	16
Bottom bracket install.....	17
Chainring install.....	22
Installing the crankset	23
Adjusting the bottom bracket.....	25
Installing the pedals.....	27
Finish touch.....	27
DISASSEMBLY	28
Crankset.....	28
Bottom bracket.....	29
MAINTENANCE	32
Important maintenance information.....	32
Disposal.....	33
Before every journey	34
Checking bottom bracket clearance	34
Regular maintenance	35
Liability for defects	37
Fair deal promise.....	37
Crash Replacement.....	37

Preface

This manual is an integral part of your THM component and it provides you with information regarding the safe operation of your THM-Clavicula crank system.

Read this manual carefully prior to assembling your THM component. Always read and observe all of the assembly and maintenance instructions in this manual, as well as those provided in the manuals of other manufacturers whose products are used on your bicycle (e.g. framchainwheels, pedals, etc.).



WARNING

Non-observance of the information contained in this manual could result in an accident and death or serious injury.

You will encounter the following symbols and references in this manual:

→ The arrow indicates the consequence of your action.



WARNING

This safety message indicates a hazardous situation which, if not avoided, could result in death or serious injury.

NOTICE

This message warns of a risk of material damage.



INFO

This refers to additional information or tips.

Retain this manual for other users of your THM components. Make sure that all users read, understand and observe this manual. If you ever sell or give away your THM components, this manual should be transferred to the new owner.

We hope you get a lot of joy from your THM components!

Your THM-Carbones Team

Intended use



WARNING

Any use differing from that intended could cause an accident and result in death or serious injury.

THM-Clavicula crank systems have been exclusively designed

- for installation on standard racing cycles, time trial and gravel.
- for the permitted area of application – see **Area of application**, page 14.

Fundamental safety precautions

The following warnings for the THM-Clavicula component apply to all Clavicula models (Clavicula Road, Clavicula MTB etc.), unless otherwise specified.

For the time being we limit the service life of your THM-Clavicula crank system to 100,000 km or 10 years. It is imperative you contact us before continuing to use your THM-Clavicula crank system after one of these limits has expired!

Always remember that riding a bicycle involves potential danger for the rider and other road users, as well as for the bicycle and its components. Even if protective equipment and safety devices are used, accidents resulting in death or serious injury can still occur.

You should therefore use your common sense and avoid any unreasonable behaviour!

Assembly & Maintenance



WARNING

Risk of accident caused by assembly and maintenance work which has not been conducted in a professional manner.

- Do not overestimate your technical ability. All assembly and maintenance work should be performed by a specialist workshop for bicycles. This is the only way to ensure the work is conducted in a professional manner.
- Always observe all of the specified tightening torques for the screw connections.
- Only use suitable, undamaged, high-quality tools.
- Only ever use original THM components which are available from your specialist dealer or directly from THM.
- Never make any modifications to your THM components.
- Check your crank system (incl. cranks, bottom bracket, chainwheels) to make sure it is undamaged and working properly before every ride. Send us your THM-Clavicula component before further use if damage is visible (cracks, fractures, deformations, etc.) or if you are in any doubt about its functionality.
- Check your THM components before each ride to ensure the surfaces are completely undamaged. Send us your THM components for inspection before further use if damage is visible (deep scratches in the paintwork which extend into the carbon structure, large abrasions, etc.), if you are in any doubt about their functionality or if the Clavicula lettering is abraded at one or more points (wear indicator).
- Always ensure your bicycle is maintained in a flawless condition. Care and maintenance will prolong the service life of your bicycle and its components and also improve your personal safety.

On the road



WARNING

Danger of accidents due to improper behaviour or improper equipment during riding.

- Always ride with foresight, attention and a readiness to brake.
- Adjust your speed to the prevailing conditions (traffic, weather, visibility, etc.).
- Do not use your THM components at ambient temperatures below -10°C (14°F).
- Do not exceed the maximum overall weight for which your THM components have been approved – see **Size**, page 10.
- Do not perform jumps with your bicycle as this generates an enormous amount of force.
- Always comply with the traffic regulations that are in force in the country where you are using your bicycle.
- When riding your bicycle you should always wear a high quality cycling helmet (e.g. ANSI certified) that is in excellent condition. Your clothing should be close-fitting but not restrictive.
- Only ride your bicycle if you are in good physical condition and your bicycle and all of its components are operating in a flawless manner.
- If you are involved in a heavy fall you should not continue to ride your bicycle. If such a case occurs, send us your THM components for inspection, even if no external damage is visible! In your own interest you should treat all of the components on your bicycle which have been produced by other manufacturers in the same manner.

Transport & Storage



WARNING

Risk of accident caused by damaged bicycle components.

- Always transport your bicycle in an appropriate and careful manner.
- Do not store your THM components at an ambient temperature below -15°C (5°F) or above 55°C (131°F).

Risk of accident.

- Do not allow children to play with your bicycle.

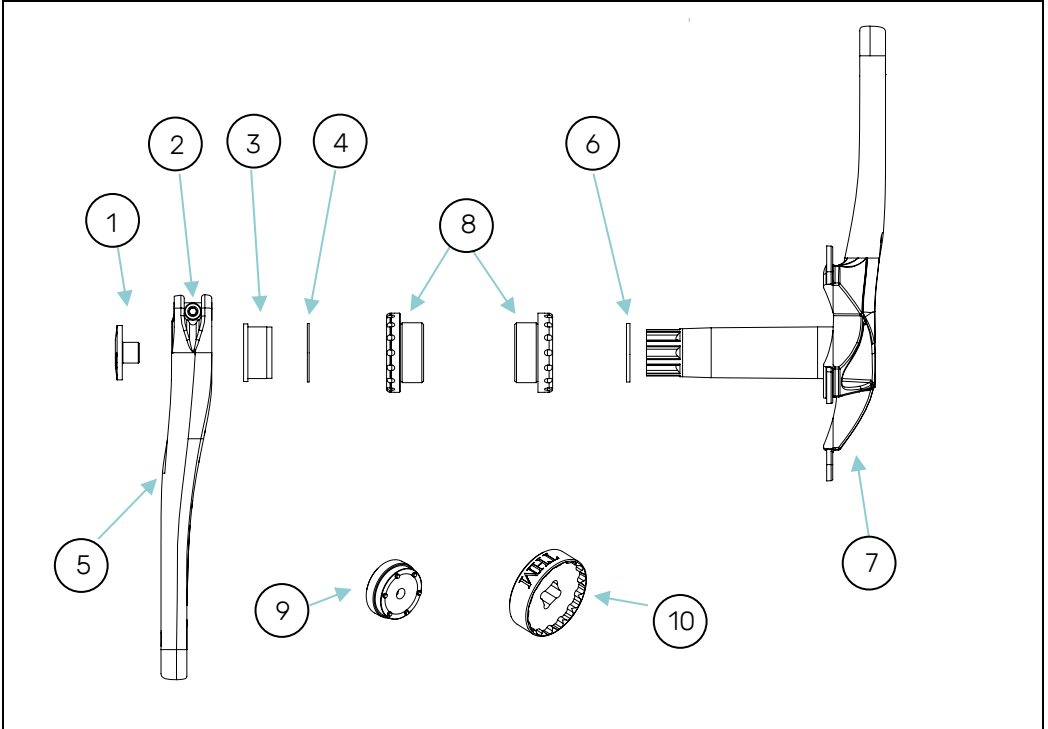
Scope of delivery

1	Adjusting screw	6	Spacer 2.0 mm
2	Clamping (screw + bolts)	7	Right crankarm (DS)
3	Cone sleeve	8	Bottom bracket (optional) - see page 11
4	Spacer 1.0 mm	9	THM adjusting tool (optional)
5	Left crankarm (NDS)	10	THM bottom bracket tool ½" Standard or T47 85,5 (optional)

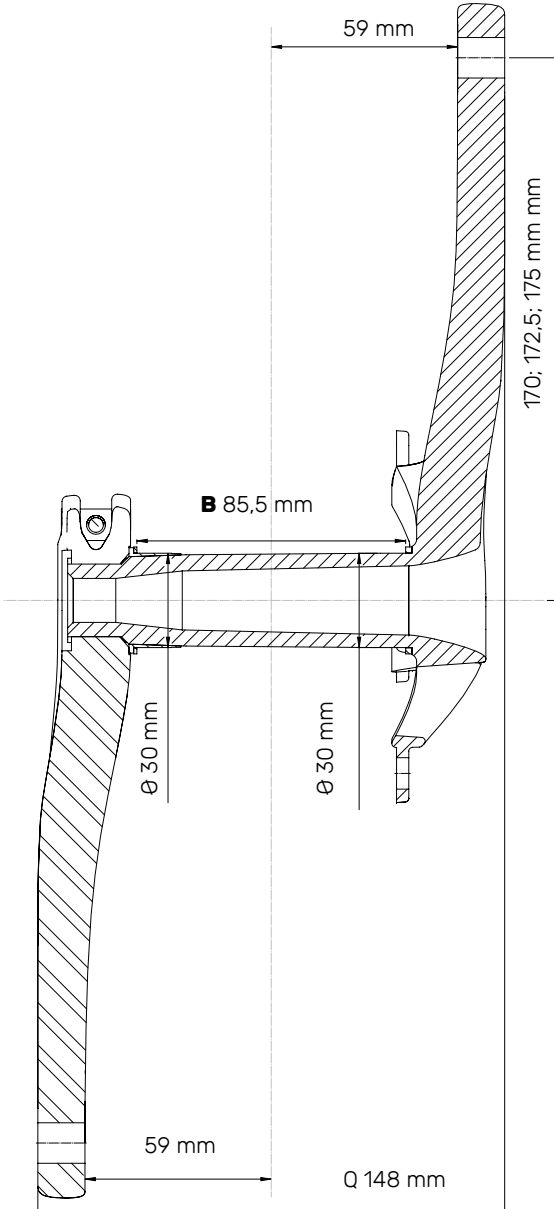
Size

Weight	293 g (0.65 lb) BCD 110 Compact 302 g (0.67 lb) BCD 130 Standard
Q-Factor	148 mm
Chainline	43,5 mm
Inner width	118 mm
Crankarm lengths	170, 172,5, 175 mm
Spindle diameter	Ø 30 mm
B overall Bottom bracket width	85,5 mm + 3 mm Spacer
Min. number of tooth:	34 teeth BCD 110 Compact 39 teeth BCD 130 Standard

THM Bottom Bracket

All Spacer configurations are **only** valid for THM Bearings. The Spacers ensure that the tapered cone sleeve has exactly the required position on the spindle. Therefore we strongly recommend THM Bearings. (see also "Installing the crankset" p.23)

There are stainless steel and ceramic hybrid bearings available.

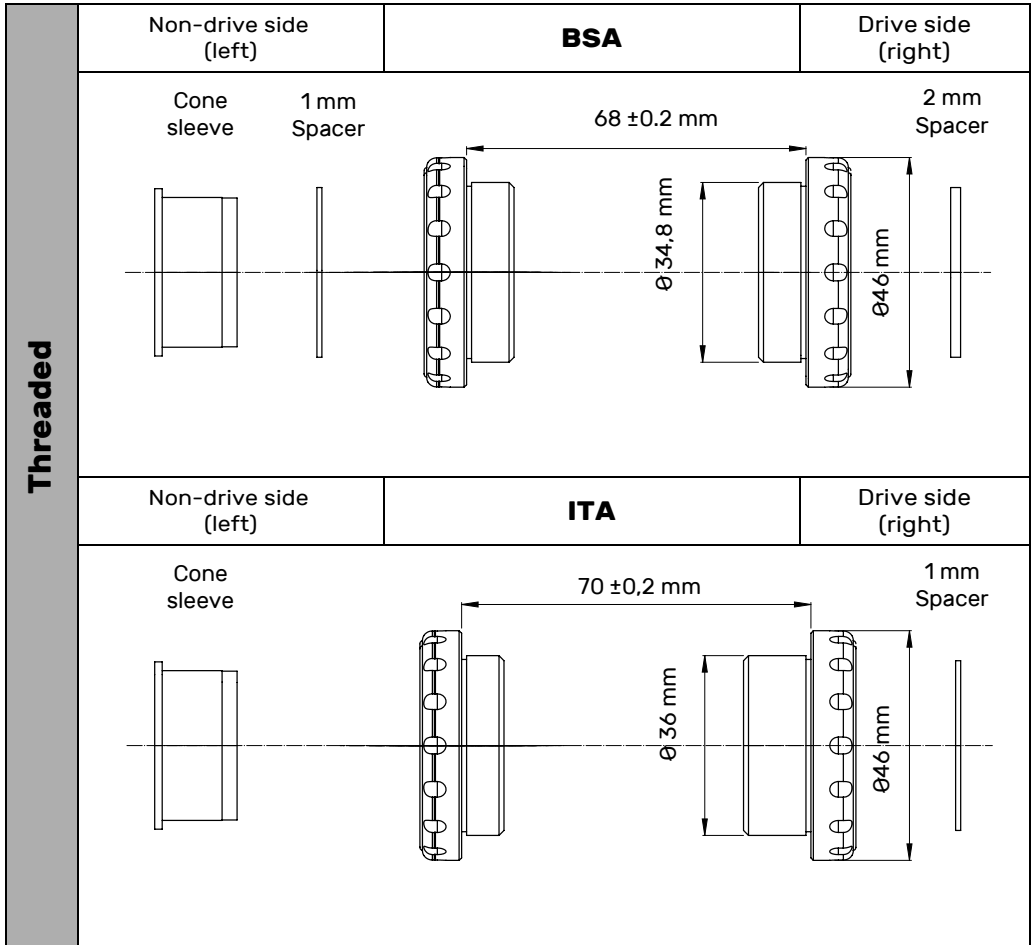

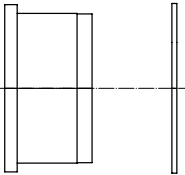
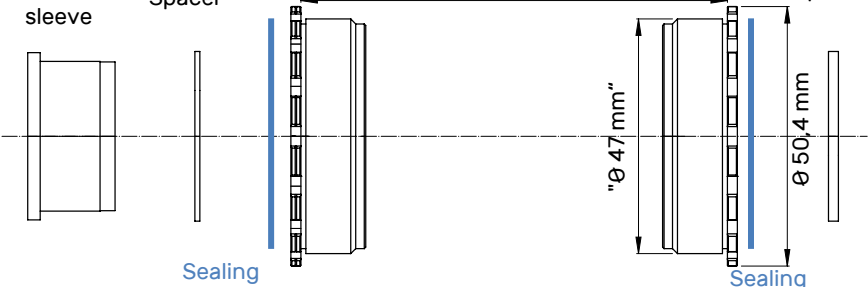
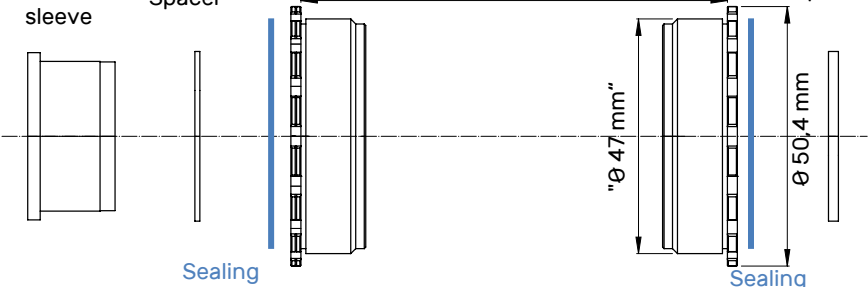
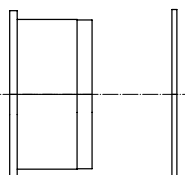
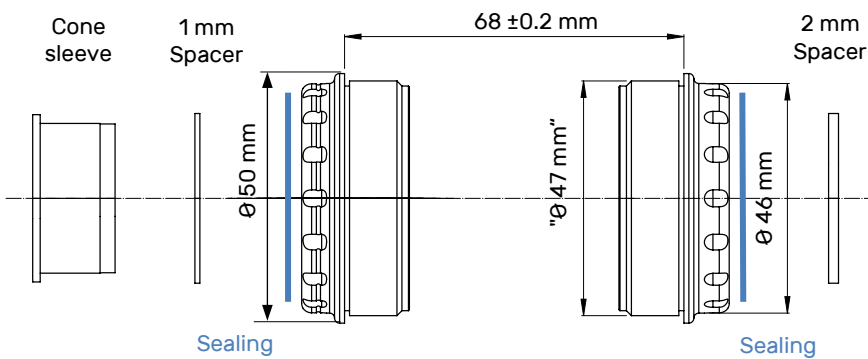
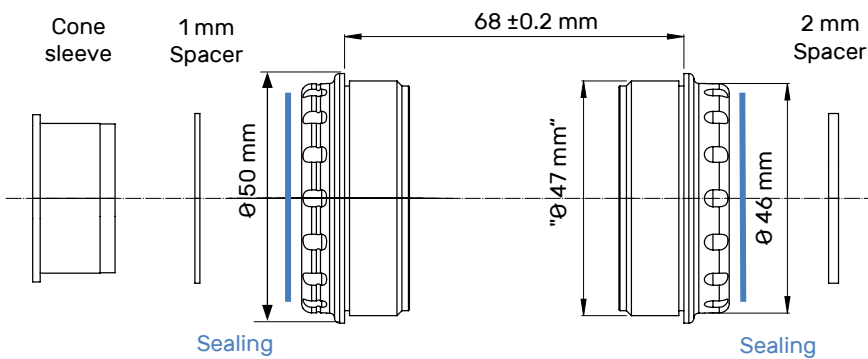
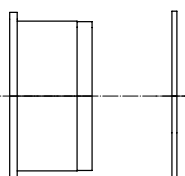
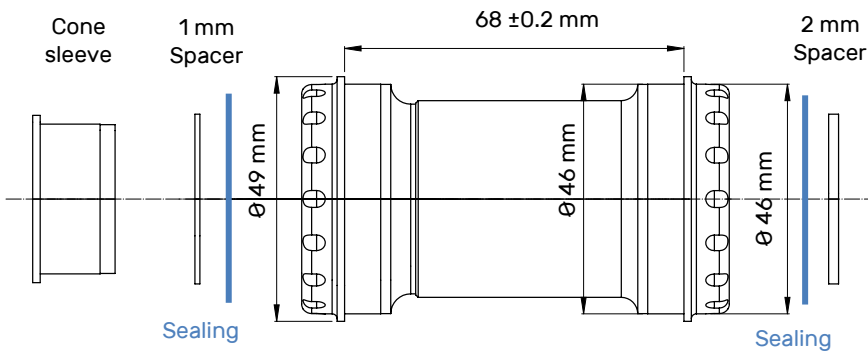
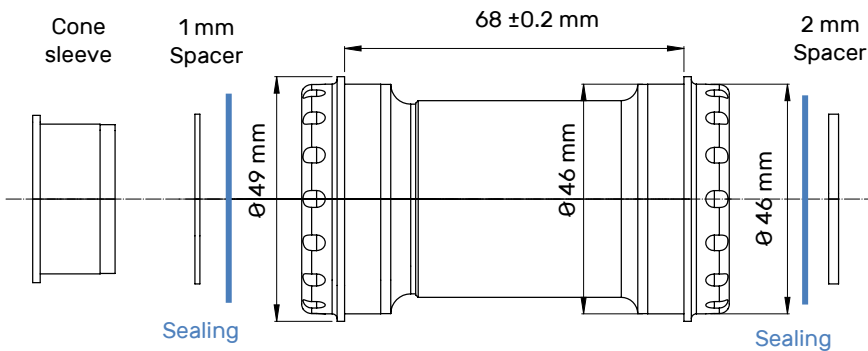
Threaded	Non-drive side (left)	T47 85,5 mm Inboard	Drive side (right)
	2,5 mm Cone sleeve 1 mm Spacer 		
Pressfit	Non-drive side (left)	T47 68 mm Outboard	Drive side (right)
	Cone sleeve 1 mm Spacer 		
Pressfit	Non-drive side (left)	PF30	Drive side (right)
	Cone sleeve 1 mm Spacer 		

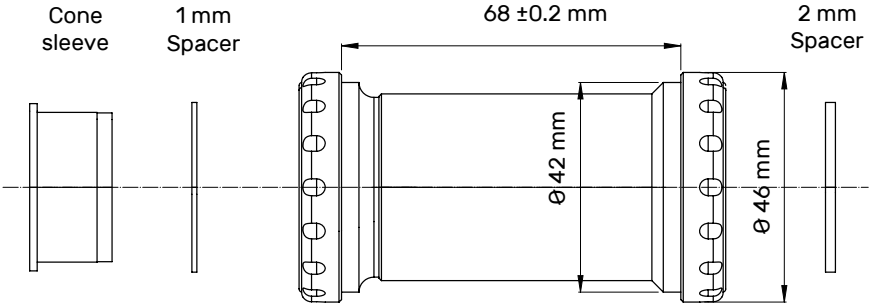
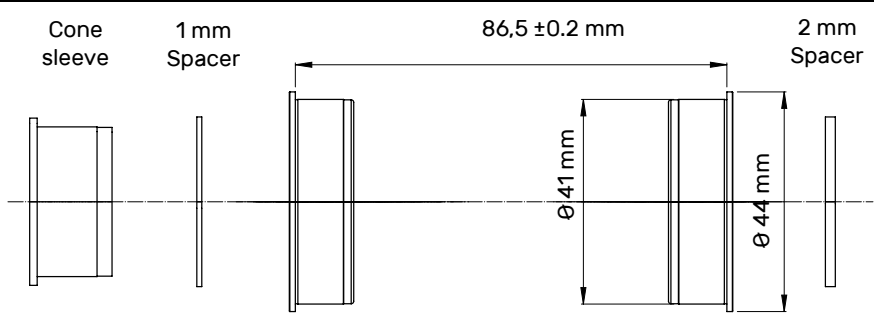
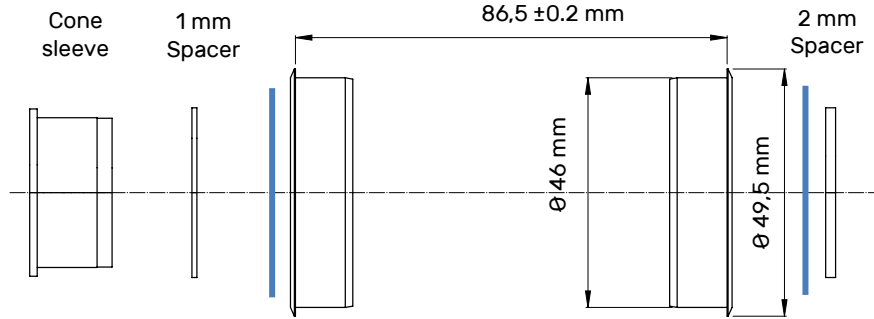
Pressfit	Non-drive side (left)	BB30	Drive side (right)
	Cone sleeve 1 mm Spacer	$68 \pm 0.2 \text{ mm}$ 	2 mm Spacer
	Non-drive side (left)	Shimano PF	Drive side (right)
	Cone sleeve 1 mm Spacer	$86.5 \pm 0.2 \text{ mm}$ 	2 mm Spacer
Non-drive side (left)	386 EVO	Drive side (right)	
Cone sleeve 1 mm Spacer	$86.5 \pm 0.2 \text{ mm}$ 	2 mm Spacer	
	Sealing		Sealing

Tightening Torques



WARNING

Risk of accident caused by a malfunctioning crank system due to loose screw connections.

- Check the required tightening torque of all screw connections after the first 100 km
- Retighten the connections if necessary. Repeat this check every 2500km!

	Nm	lbf ·in	
Adjusting screw	8	89	with thread lock
Crank clamping bolt	10	89	
Bearing cups	40	354	greased
Chainwheel bolts, aluminium	6	53	
Pedal threads	20	177	

Application area



WARNING

Risk of accident caused by a malfunctioning crank system due to overload.

- Only ever use your Clavicula component within its permitted area of application.

Clavicula SE	X1-X2
---------------------	-------

X1 Racing cycle and light cross-country terrain

X2 Touring, road

X3 medium/heavy terrain

X4 Free ride, heavy terrain

X5 Downhill, extreme terrain

General Information



WARNING

If not properly performed, assembly and maintenance work could cause accidents resulting in serious or fatal injury.

- Do not overestimate your technical ability. All assembly and maintenance work should be performed by a specialist workshop for bicycles. This is the only way to ensure the work is conducted in a professional manner.

Preparing the Frame



INFO

It is imperative you read and observe the safety and assembly information provided by the manufacturer of your frame.

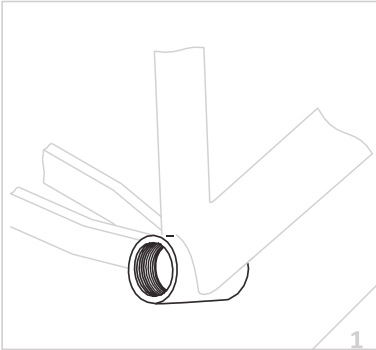

- ☞ Secure your bicycle in an appropriate assembly stand.
- ☞ If necessary remove the crankset and the old bottom bracket.
- ☞ If necessary use cleaning solvent or other similar agents to clean the bottom bracket housing of your frame.
- ☞ Make sure that the edges of the bottom bracket housing are plane, parallel, milled to the correct dimension and free of burrs – page 11.
If necessary rework the bottom bracket housing using an appropriate milling tool (Cyclus, ParkTool® or other similar tool).
- ☞ Make sure that the threads of the bottom bracket housing are clean, free from paint residues and adequately tapped into the housing.
If necessary, rework the threads with an appropriate cutting tool (Cyclus, ParkTool® or other similar tool).

Bottom bracket install

To find the required bottom bracket, please measure the inner diameter and the width of the bottom bracket housing of your bicycle frame.

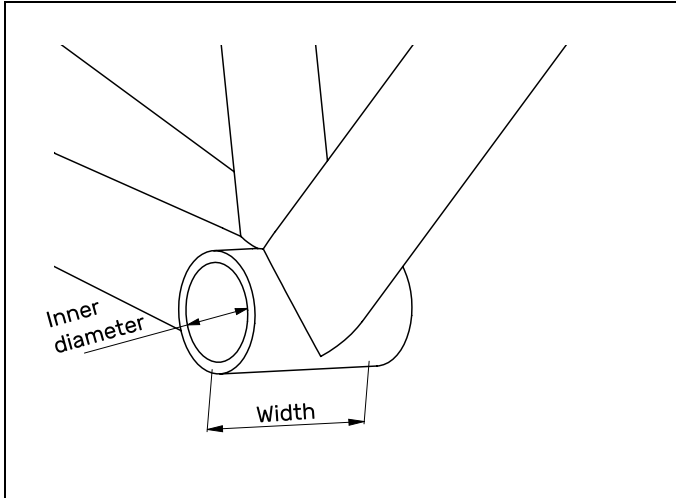

Also check if you need threaded or pressfit bearing shells. The following table will show you which THM bottom bracket you need:

	Inner Diameter	Width	Bottom bracket
Threaded	33,8 mm	68 mm	BSA
	34,8 mm	70 mm	ITA
	46 mm	85,5 mm	T47 85,5 inboard
	46 mm	68 mm	T47 68 outboard
Pressfit	46 mm	68 mm	PF 30
	42 mm	68 mm	BB 30
	41 mm	86,5 mm	Shimano PF
	46 mm	86,5 mm	386 EVO
	46 mm	79 mm	BBRight PF Road

Make sure that the securing bolt of the derailleur cable guide does not protrude into the bottom bracket housing by more than 1 mm.

Apply grease to the threads and contact surfaces of the bearing cups.

BSA / ITA

INFO

The non-drive (left) side bearing cup is marked with a groove

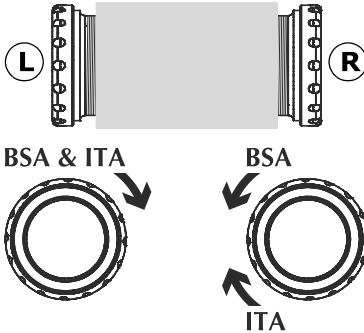

- Screw the right – hand bearing cup(R) (initially by hand) into the drive side of the bottom bracket housing.
- For BSA screw **anticlockwise!**
- For ITA screw **clockwise!**
- Screw the left-hand bearing cup(L) (initially by hand) into the non drive side of the bottom bracket housing.
- For BSA and ITA screw clockwise!

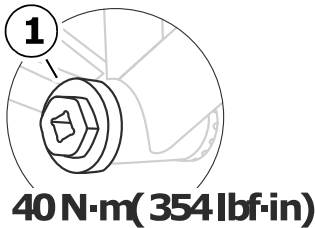

- Use the THM Bottom bracket tool ½ " **(1)** torque wrench to apply 40 Nm

T47 inboard and outboard



INFO

The non-drive side bearing cup is marked with a groove

NOTICE

Due to the limited length of the crank axle the T47 inboard bottom bracket works only with 85,5 mm bottom bracket width! Ensure that your frame is not 86,5 mm!

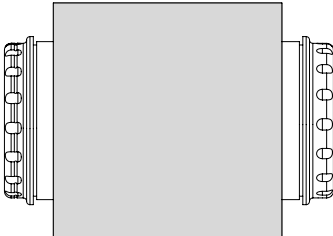
Non-drive-side (left)	Drive-side (right)
Screw the left-hand bearing cup(L) (initially by hand) into the non drive side of the bottom bracket housing. Screw clockwise! Place the sealing.	Screw the right-hand bearing cup(R) (initially by hand) into the drive side of the bottom bracket housing. Screw anticlockwise! Place the sealing.
<h3>T47 85,5 mm Inboard</h3> <div style="display: flex; justify-content: space-between; align-items: center;"> <div data-bbox="191 951 351 1050" style="width: 30%;"> Tool THM T47 IL or BBT 50.4 mm 12 notch 40 Nm </div> <div data-bbox="390 890 723 1110" style="width: 40%; text-align: center;">  </div> <div data-bbox="810 951 971 1050" style="width: 30%;"> Tool THM T47 IL or BBT 50.4 mm 12 notch 40 Nm </div> </div>	
<h3>T47 68 mm Outboard</h3> <div style="display: flex; justify-content: space-between; align-items: center;"> <div data-bbox="180 1286 340 1358" style="width: 30%;"> THM Standard Bottom bracket Tool 40 Nm </div> <div data-bbox="393 1225 725 1461" style="width: 40%; text-align: center;">  </div> <div data-bbox="810 1286 971 1358" style="width: 30%;"> THM Standard Bottom bracket Tool 40 Nm </div> </div>	

BB30 / PressFit 30 / BBright™ PressFit



INFO

For BB30, PressFit 30 and BBright™ PressFit bottom brackets:

The long bearing cup with internal thread is always located on the drive side.

The short bearing cup with external thread is always located on the non-drive side.

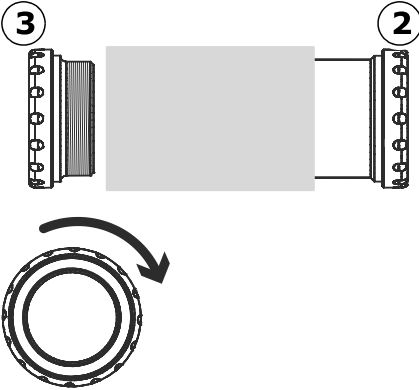
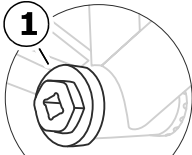
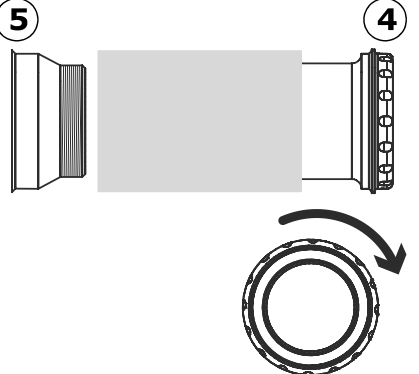
<p style="text-align: center;">BB30 / PressFit 30</p> 	<ul style="list-style-type: none"> - Apply grease to the threads and all fits. - Insert the long bearing cup (2) or (4) by hand as far as possible into the drive-side of the bottom bracket housing. - Screw the short bearing cup (3) or (5) by hand as far as possible into the right-hand bearing cup using a clockwise rotation. - Make sure that both bearing cups are located centrally in front of the bottom bracket housing. - Use the THM Bottom bracket tool ½ " (1) torque wrench to apply 40 Nm  <p style="text-align: center;">40 N·m (354 lbf·in)</p> <ul style="list-style-type: none"> - For PressFit 30 place the sealings
<p style="text-align: center;">BBright PressFit™</p> 	

Shimano® Press-fit / 386EVO

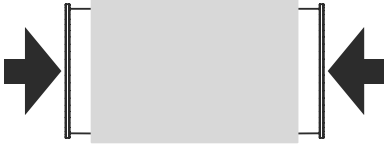

- Press both bearing cups simultaneously into the bottom bracket housing as far as possible by using a suitable pressing tool (e.g. ParkTool®).
- For 386 EVO place the sealings

Chainring install

The Clavicula SE is designed for 2 chainrings. But of course you can install a 1x chainring. Please note for this purpose we offer special washers to distribute the load evenly on the carbon structure.



WARNING

Danger of damage to the chainring mount .

- The number of chainwheel teeth must never be less than the minimum number required – see page 11.
- Always observe the tightening torques specified by the manufacturer of the chain ring bolts; however, do not exceed a max. tightening torque of **6 N·m (53 lbf·in)** under any circumstances.

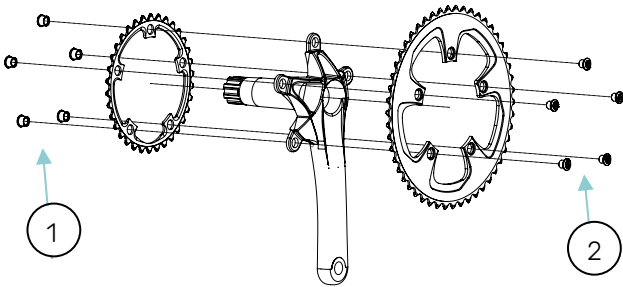
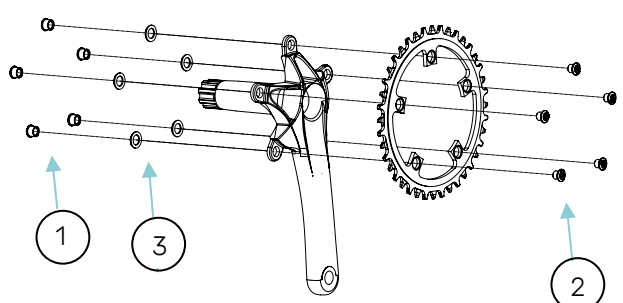
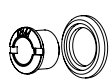
	<h3>Install 2 chainrings</h3> <ul style="list-style-type: none"> - Place the small chainring with the chainring nuts (1) on the inside - Apply grease to the screws (2) - Place the big chainring on the outside and tighten the chainring screws (2) to 6 Nm
	<h3>Install 1 chainring</h3> <ul style="list-style-type: none"> - Place the washer (3) on the chainring nut (1):  - Place both on the crank and place the chainring on the outside. - Apply grease on the screws (3). - Tighten the screws (3) to 6 Nm

Installing the crankset

Before installing the crankset please check if the bottom bracket is correctly installed and runs smoothly. For T47, Pressfit 30 and 386 EVO please check if the sealing is mounted. This description is only valid if you use THM bottom bracket which are designed for the THM cranksets.



WARNING

If you use non THM bearings please check if the width (see Specifications) of the bearings allows for the cone sleeve to be installed in the correct position as described in this chapter.

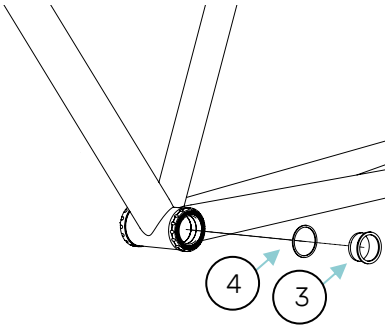
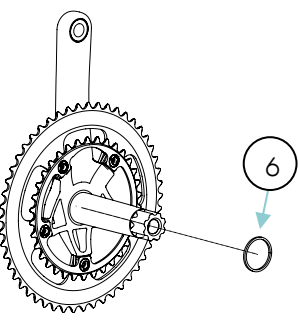
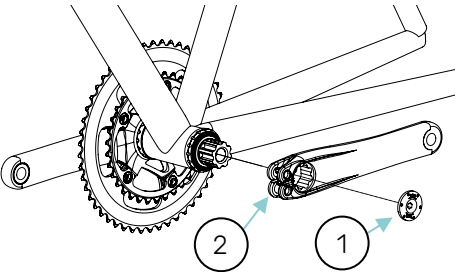
	<ul style="list-style-type: none"> - Locate the 1.0 mm spacer (4) ring on the cone sleeve (3). (For T47 inboard bottom bracket use a cone sleeve with 2.5 mm flange.) - Except for ITA there is no spacer needed on the cone sleeve. - For BBright™ PressFit Road take a 2.0 mm spacer - Press the cone sleeve in the bearing on the non-drive side (left)
	<ul style="list-style-type: none"> - Place a 2 mm spacer (6) ring onto the axle. (see also p. 11 ff). - For ITA and BBright PressFit Road use a 1 mm spacer instead of 2 mm. - Lightly grease the bearing seat of the axle. - Insert the axle of the right crank through the bottom bracket up to its stop.
	<ul style="list-style-type: none"> - Thoroughly degrease the axle and crank multi-tooth segment. - Make sure that the clamping screw (2) is loosened or removed - Fit the left crank arm to the multi-tooth segment of the axle. - Press the cranks together by hand as far as possible. Both cranks abut against the spacer rings.

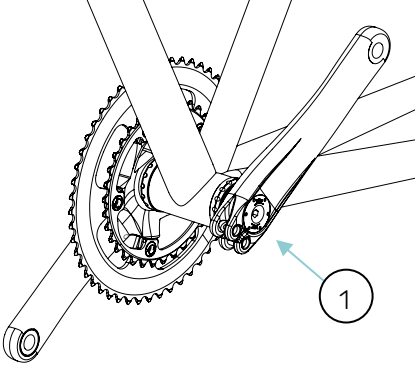
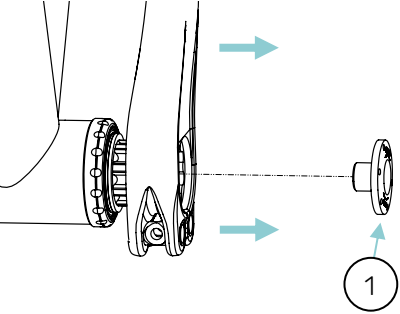
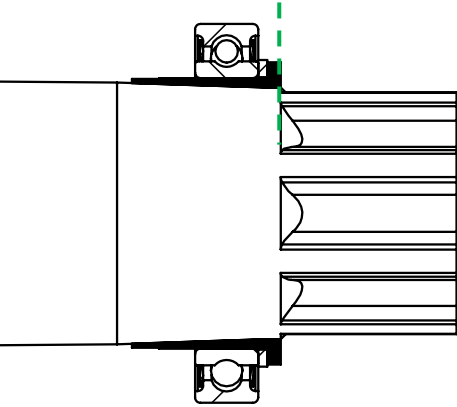
	<ul style="list-style-type: none"> - Screw the adjusting screw (1) into the axle – use the THM adjustment tool, or a 6 mm allen key for this. <p>tighten = screw anticlockwise! loosen = screw clockwise!</p> <ul style="list-style-type: none"> - Tighten the adjusting screw until the collar on the cone sleeve is flush against the bearing or spacer ring. The tightening torque required for this is typically 5-10 Nm (44-106lbf·in) – depending on the actual width of the bottom bracket housing.
	<ul style="list-style-type: none"> - Check the clearance between the cranks, chainrings and the chainstays of the frame. - Minimum clearance: 3mm. - Remove the adjusting screw (1). - Pull the crank arm a little off the axle (3-5 mm)
	<ul style="list-style-type: none"> - Check if the cone sleeve (black) is flush with the end of the multi segment area (green marked line) or up to 1.5 mm more towards the chainrings. - If the cone sleeve is not in the position described above this can lead to premature wear.

Adjusting the bottom bracket

i INFO

Accelerated bearing wear if the bottom bracket is set too rigidly due to excessive pre-tensioning of the adjusting screw.

-Only adjust the bottom bracket if the clamping screw has been loosened! As a rule, the required tightening torque of the adjusting screw for a correctly adjusted bottom bracket is approximately 0.3-1N•m (3-9lbf•in).

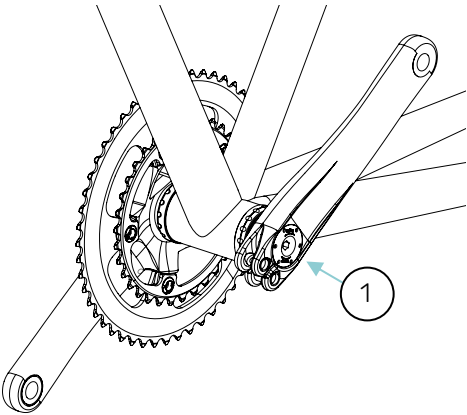
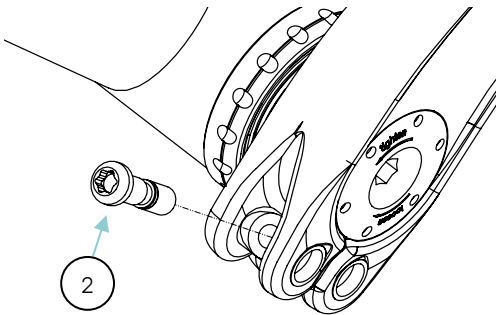
	<ul style="list-style-type: none"> - Clean the threads of the adjusting screw (1) - Apply a medium-strength thread lock (Loctite or other similar) to the thread of the adjusting screw. - Screw the adjusting screw (1) into the axle - when doing this use the THM adjusting tool or a 6 mm allen key. - Tighten the adjusting screw carefully and slowly until the bottom bracket does not exhibit any play, but can still be turned easily by hand. - Adjustment of the bottom bracket is now complete.
	<ul style="list-style-type: none"> - Remove the clamping screw (2). - Apply a medium-strength thread lock (Loctite or other similar substance) to the thread of the clamping screw. - Reassemble the clamping screw. - Tighten the clamping screw to 10 Nm (89lbf•in).

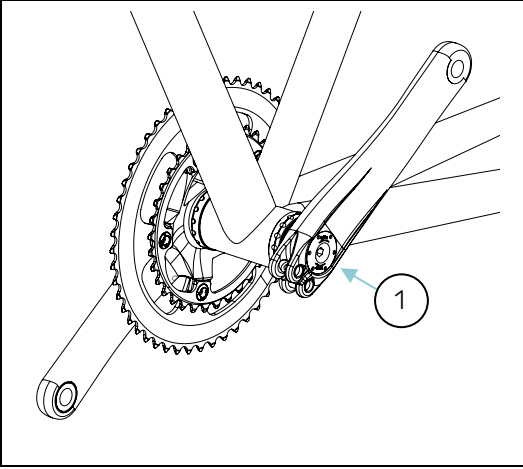

- Tighten the adjusting screw **(1)** to **8 Nm (71lbf-in)** to prevent losing it.
- Installation of your Clavicula component is now complete.

WARNING

Risk of accident caused by a malfunctioning crank system due to loose screw connections.

- Allow the thread lock to harden in line with the manufacturer's specifications before using your Clavicula component.

Installing the pedals

INFO

Pedals are manufactured with Right-hand thread for Right-hand pedals (drive side) and Left-hand thread for Left-hand pedals.

It is essential not to confuse the RH and LH pedal!

- Follow the instructions of the pedal manufacturer
- We highly recommend to apply grease on the pedal threads

WARNING

Risk of damage to the carbon structure around the pedal threads.

- Do not exceed the maximum tightening torque for the pedals prescribed by THM max. **20 Nm (177 lbf·in)**!

Finish touch

- Check the position and adjustment of the front derailleur as well as the chain line.
- Readjust the front derailleur if required.

WARNING

Risk of accident caused by a malfunctioning crank system due to loose screw connections.

- Check the required tightening torque of all screw connections after the first 100 km
 - retighten the connections if necessary. Repeat this check every 2500 km!
 Apply fresh thread lock if necessary.

Risk of accident caused by a malfunctioning crank due to wear.

- Do not continue to use your Clavicula component if the Clavicula lettering is abraded at one or more points (wear indicator).

INFO

Please note that if you use overshoes, or if there is an extremely small clearance between the brake shoe and crank, it will cause the crank surface to wear. This level of wear is increased significantly if the bike is used frequently in wet and dirty conditions! You can prevent this wear by sticking an appropriate protective film (Lizard Skins or other similar film) over the areas that are susceptible to wear. Check these areas for wear at regular intervals!

Crankset

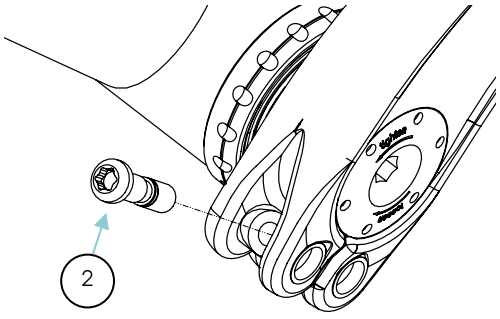
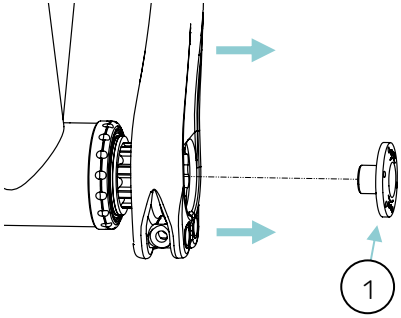
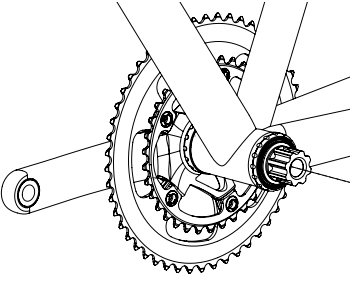
	<ul style="list-style-type: none"> - Loosen the clamping screw (2)
	<ul style="list-style-type: none"> - Loosen (screw clockwise) the adjusting screw (1) and remove it. - Pull off the left crank arm (non-drive-side).
	<ul style="list-style-type: none"> - Take off the chain from the chain rings - Pull out the right crank (drive-side). If it is stuck in the bearings you can gently tap the axle with a soft-face hammer.

Bottom bracket
BB30 / PressFit 30

INFO

When dealing with BB30, PressFit 30 and BBright™ PressFit bottom brackets the bearing cup with internal thread **(1)** or **(3)** is always located on the drive side (right), while the bearing cup with external thread **(2)** or **(4)** is always located on the non-drive side (left).

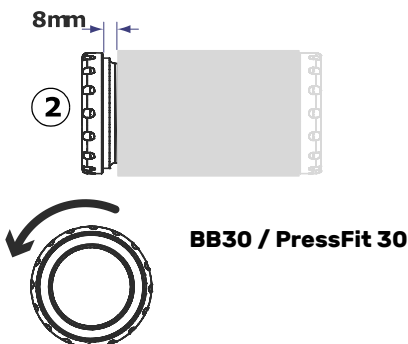
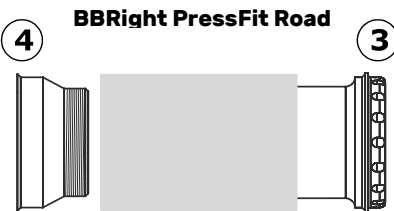
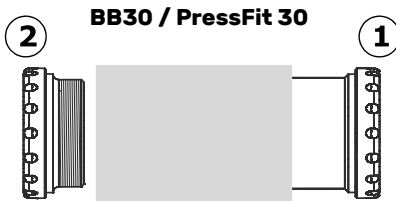

- Loosen the bearing cup **(2)** or **(3)** using an anticlockwise rotation until there is a gap of approx. 8 mm between the bearing cup and bottom bracket housing.

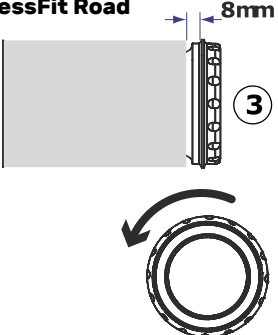
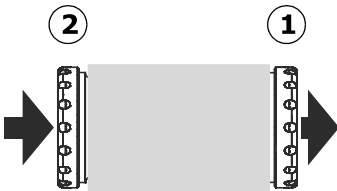
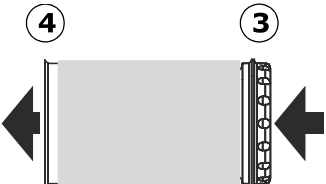
<p>BBRight PressFit Road</p> 	
<p>BB30 / PressFit 30</p> 	<ul style="list-style-type: none"> - Use a rubber mallet to carefully tap the bearing cup (2) or (3) until the bearing cup (1) is extracted from the bottom bracket housing.
<p>BBRight PressFit Road</p> 	<ul style="list-style-type: none"> - Now twist the bearing cups apart by hand and remove them from the bottom bracket housing.

Pres Fit / EVO386/BBright™ Direct Fit



INFO

Remove the Press-fit / EVO386 / BBright™ Direct Fit bottom bracket by using a suitable extraction tool (e.g. Birzman BM16-HUCR, VAR DR-37400).



INFO

Please contact us **before** returning a defective THM product!

If products are returned without our previous agreement, the shipping costs incurred will be charged to your account and, furthermore, we also reserve the right to refuse acceptance of the product.

When returning a defective THM product to us please ensure adequate postage costs are provided. Any shipment which is not prepaid will be rejected and returned to the sender!

Important maintenance information



WARNING

If not properly performed, assembly and maintenance work could cause accidents resulting in death or serious injury.

- Do not overestimate your technical ability. All assembly and maintenance work should be performed by a specialist workshop for bicycles. This is the only way to ensure the work is conducted in a professional manner.

Improperly performed assembly and maintenance work could also result in a loss of your warranty rights (liability for defects)!



WARNING

Risk of accident caused by damaged components.

- Never attempt to disassemble your THM-Clavicula component - only THM employees are authorised to do this.
- Always read and observe all of the assembly and maintenance instructions in this manual, as well as those provided in the manuals of other manufacturers whose products are used on your bicycle (e.g. frame, chainwheels, pedals, etc.).
- Always observe the minimum and maximum values specified - see **Specifications**, from page 9.
- Only use suitable, undamaged, high-quality tools.
- When conducting assembly steps that require a specific tightening torque, always use an appropriate torque wrench that is designed for the tightening torque specified.

NOTICE

- Never use a high-pressure cleaner or steam cleaner to clean your bicycle, as the seals of your bicycle components are not able to withstand the pressure. If such cleaners are used, it would result in corrosion and material damage.
- Never use caustic solvents (such as paint thinners, acetone, nitro compounds, etc.) as they can attack the surface of your THM components.
- Only use commercially available paint care products and water to clean your THM components. Spirit or petrol should be used carefully when using such products. Avoid excessive wiping and prolonged exposure times.

Always ensure your bicycle is maintained in a flawless condition. Care and maintenance will prolong the service life of your bicycle and its components and improve your personal safety!

If you suspect that your bicycle is defective or is not functioning properly, stop using it and contact a specialist bicycle workshop immediately!

Disposal

If THM components are defective or no longer in use, you can dispose of them with your non- recyclable waste or domestic refuse, or ask a local waste disposal company for other disposal methods (e.g. recycling).

Before every journey



WARNING

Risk of accident caused by material damage or improper assembly.

- Check your THM components before each journey to ensure the bonded joints are completely undamaged. Send us your THM components for inspection before further use if damage is visible (cracks, fractures, clicking sounds, wobbling, etc.) or if you are in any doubt about their functionality.
- Check your THM components before each journey to ensure the surfaces are completely undamaged. Send us your THM components for inspection before further use if damage is visible (deep scratches in the paintwork which extend into the carbon structure, large abrasions, etc.), if you are in any doubt about their functionality or if the Clavicula lettering is abraded at one or more points (wear indicator).
- Do not exceed the maximum overall weight for which your THM components have been approved see **Size**, page 9.

Checking bottom bracket clearance

NOTICE

Risk of damage to the bearings.

- Never try to remove the bearing seals from the bottom bracket.
 - Your THM bottom bracket is elaborately sealed and provided with permanent lubrication. There is no need to re-lubricate the bearings!
-
- Grasp both cranks of your bicycle.
 - Try to move the cranks to the left and right.
 - If you feel bearing play, it means that the bottom bracket is loose and needs to be adjusted immediately
 - see **Adjusting the bottom bracket**, page 20.
 - Now shift the chain onto the smallest chainwheel.
 - Remove the chain from the chainwheel and place it onto the bottom bracket housing.
 - The bottom bracket can now be rotated freely.
 - Use two fingers to grasp one of the cranks directly by the bottom bracket axle and rotate the axle in its bearing.
 - If the bottom bracket axle rotates with perceptible resistance, it means that the bottom bracket is too tight and must be adjusted immediately – see **Adjusting the bottom bracket**, page 20.

Regular maintenance

The maintenance intervals required for your bicycle depend on how often and in which weather conditions it is used.

The following maintenance measures should be conducted more frequently if the bicycle is used in extreme conditions (rain, dirt, long distances, etc.).

When conducting regular maintenance procedures make sure your bicycle is always clean and well protected by lubricants and cleaning agents. Ask your specialist dealer about appropriate lubricants and cleaning agents as well as information relating to their correct application.



WARNING

Risk of accident caused by a malfunctioning crank system due to loose screw connections.

- Check the required tightening torque of all screw connections after the first 100 km re-tighten the connections if necessary. Repeat this check every 2500km! Apply fresh thread lock if necessary.

Risk of accident caused by a malfunctioning crank due to wear.

- Do not continue to use your Clavicula component if the Clavicula lettering is abraded at one or more points (wear indicator).

Risk of accident caused by malfunctioning brakes.

- After conducting any cleaning, maintenance or repair work make sure that the braking rims of your wheels are free from lubricants (such as grease, oil, silicon, Teflon, wax or other similar agents).

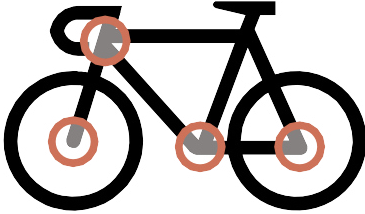
NOTICE

1

- Never use a high-pressure cleaner or steam cleaner to clean your bicycle, as the seals of your bicycle components are unable to withstand the pressure. This will result in corrosion and material damage.
- If you are using a hose, handle it with care - never aim the hose directly at the bearing components (fig. 1).

- Clean your THM-components at regular intervals by using water and a non-abrasive, environmentally friendly cleaning agent.
- When cleaning your THM components always check for signs of damage (dents, cracks, scratches, large abrasions, worn areas, etc.).
- Periodically preserve the surface of your THM components using a high quality protective wax or other similar agent.

Liability for defects

We provide a warranty for all THM products which covers material and processing defects.

We will replace defective products at no cost to the user within this period.

The liability period starts at the time the relevant THM product was purchased. Liability does not extend to any kind of damage caused by normal wear and tear, accidents, unauthorized modifications, negligence or improper handling and use.

Liability shall expire if repair work or any other work on the THM product has been conducted by unauthorized persons.

The same shall also apply to any direct or indirect damage resulting from an action described in the preceding sentence.

Fair deal promise

Minor damage to your THM products will be repaired by our workshop free of charge even after expiration of the legal liability period, provided that the work required does not exceed 0.5 hrs.

The decision regarding whether or not a repair is to be carried out free of charge rests solely with us. If the damage has been self-inflicted, there is no entitlement to free repair work!

In the event of self-inflicted damage please send us the product concerned for inspection. After we have assessed the overhead for the required repair, we will either perform the repair free of charge, or we will send you a cost estimated. It is then up to you to decide whether or not to go ahead with the repair work.

Crash Replacement

In the event of irreparable damage (e.g. caused by accident) we will provide a 40% discount from the respective list price if you purchase a new THM product as a replacement.

The relevant claim must be forwarded directly to THM Faserverbund-Technologie GmbH. The irreparable product shall then remain our property.

The company THM Faserverbund-Technologie GmbH is constantly striving to improve product designs as technical developments continue. We therefore reserve the right to make alterations which must not correspond to the text and illustration contained in this manual, and without incurring obligation to alter any products previously delivered.

Technical specifications, dimensions and weights are to be understood with the corresponding allowances.

Reproduction or translation of this publication, in whole or in part, is not permitted without the written consent of the company THM Faserverbund-Technologie GmbH. All rights under the provisions of the copyright act are reserved.

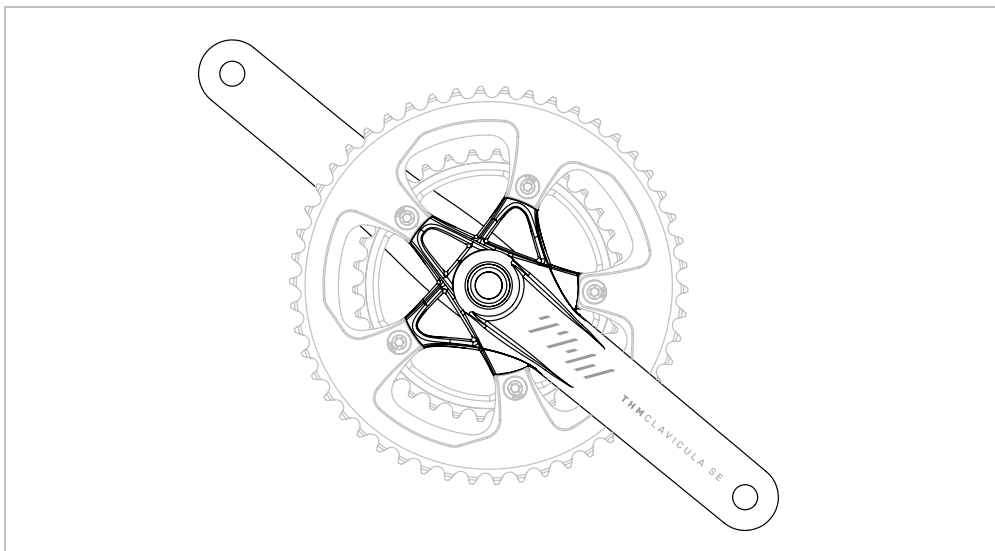

THM Faserverbund-Technologie GmbH
Am Sportplatz 3
D-24791 Alt Duvenstedt
Germany

info@thm.bike

www.thm.bike