

PRAXIS

ALL CHAINRING GUIDES

- MTN DM 1X - CHAINLINES / OFFSETS
- WAVE RING - CORRECT CHAIN SET UP
- MTN | THREADED STEEL E-RING SETUP
- 1X 110BCD ROAD RING - INSTALL/MOUNTING
- 2X RING SETUP INSTALL/ALIGNMENT
- ROAD 2X BOLT CIRCLE 110BCD/130BCD
- ROAD 2X CATCH PINS
- ROAD 2X 48/32 110BCD GUIDE

GEN1

OLDER PRAXIS MTN CRANKS

THE OLDER GEN1 MTN CRANKS HAD DIFFERENT SPACING.

FOLLOW THESE OFFSETS FOR CORRECT CHAINLINES

RING OFFSET 3mm 0mm -1mm

- 1mm "DMC" OFFSET = 56MM CL "Super Boost"
- 0mm "DMB" OFFSET = 52MM CL "Boost"
- 3mm "DMA" OFFSET = 49MM CL "Non Boost"

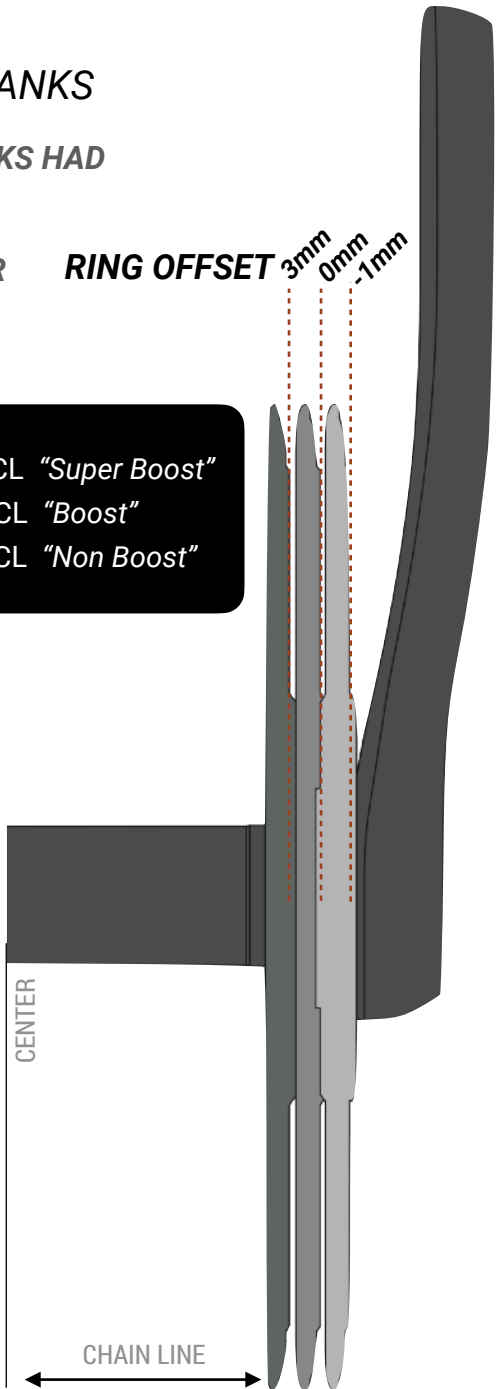

NEW GEN2

PRAXIS MTN CRANKS

RING OFFSET

6mm 3mm 0mm -1mm

- 1mm OFFSET = 56MM CL "SuperBoost"
- 0mm OFFSET = 55MM CL
- 3mm OFFSET = 52MM CL "Boost"
- 6MM OFFSET = 49MM CL "Non Boost"



IDENTIFIER - THIS CL GUIDE DECAL IS ON BACK OF ALL GEN2 PRAXIS MTN DRIVE ARMS!

VISUAL REFERENCE GEN2 MTN CRANK GRAPHICS

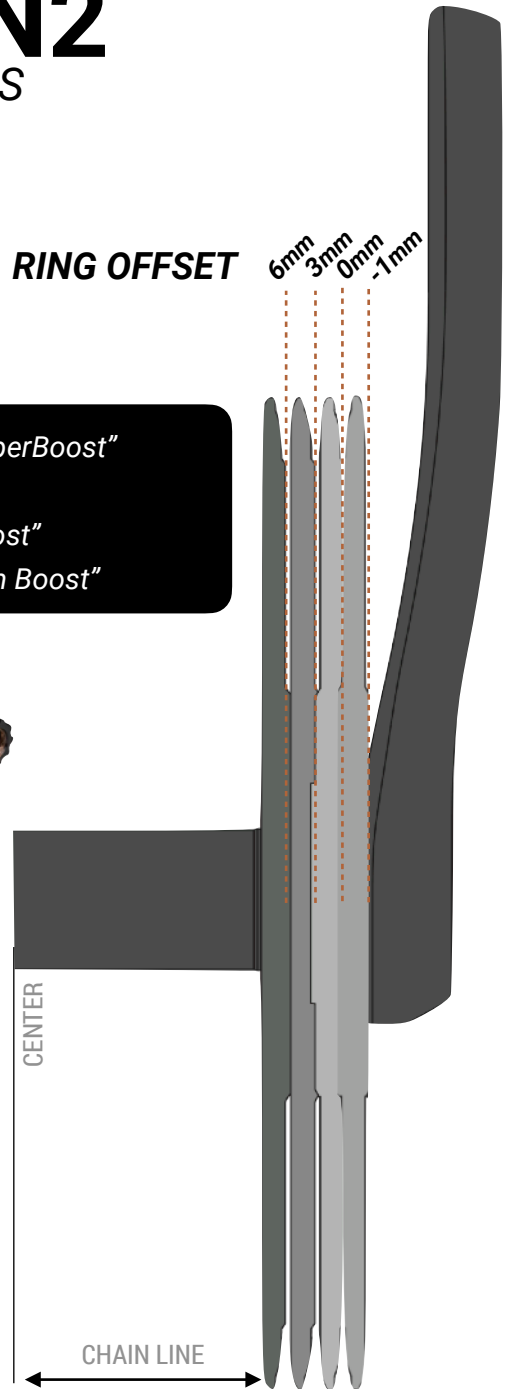

VISUAL REFERENCE OLDER GEN1 MTN CRANK GRAPHICS





ALIGN "OUTER" LINK WITH "INNER" TOOTH!

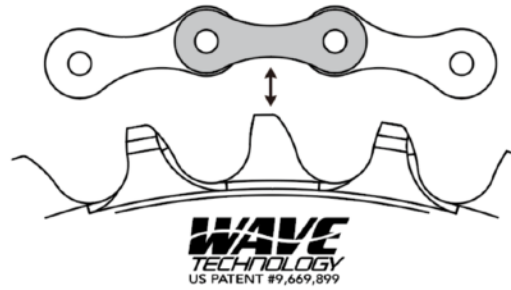

CHAIN INSTALLATION : Using the icon on your Wave Ring, Make sure your chain is aligned and placed correctly on the Wave Tech ring or *chain will not sit down and ride on teeth correctly.*



DM RING INSTALLATION

ROAD & MTN CRANKS

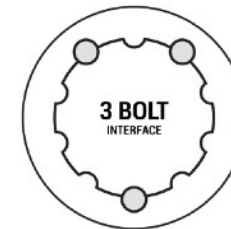

9Nm - T25 Torx Bolts

CLEAN & GREASE : *The interface surface where ring mounts.*

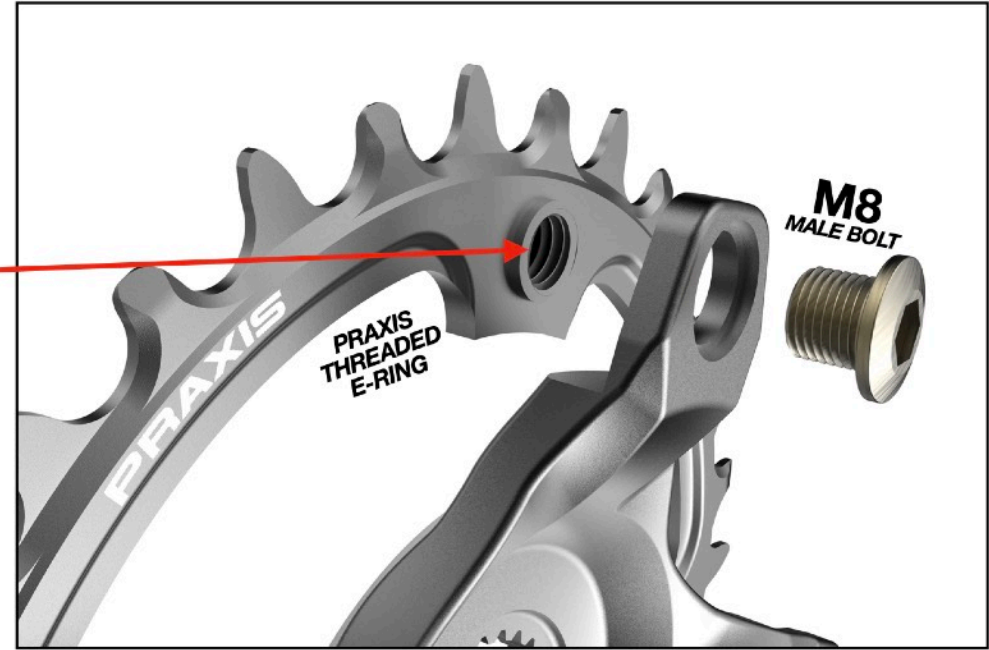

PRAXIS E-RINGS ARE THREADED FOR M8 BOLT
THIS IS FOR MOTOR CLEARANCE AND EASIER RING INSTALL/REMOVAL

M8
CHAINRING BOLT

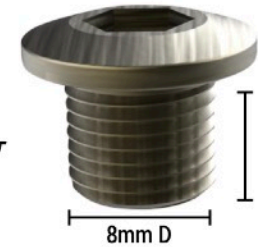

7mm Thread
Length Min.

8mm D



RING MOUNTING - PRAXIS LOGOS FACE OUTWARD!

CORRECT MOUNTING 1X 110BCD



TREK - Domane HP+
Specialized - Creo Family

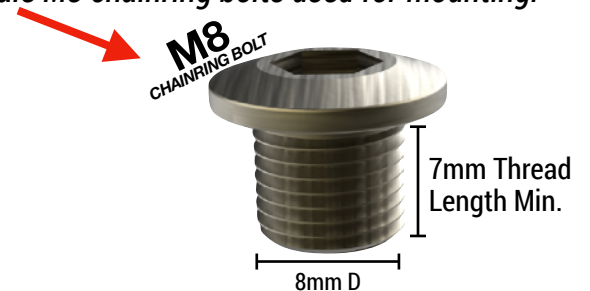

CORRECT MOUNTING
SUPPORT CORRECT
MONTAGGIO CORRETTO
MONTAJE CORRECTO
KORREKTE MONTAGE
CORRECTE STEUN
正確的掛接
画像としてインストールしなさい

**ALIGN THE MARKINGS
ON BACK OF RING SET**

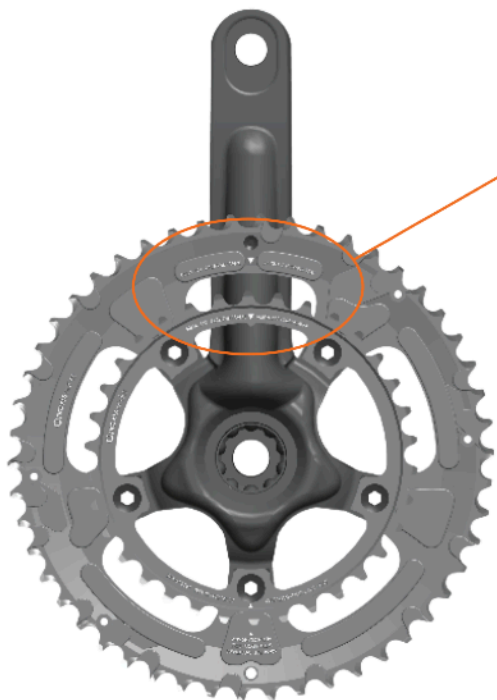

TRADITIONAL 5-ARM MOUNT

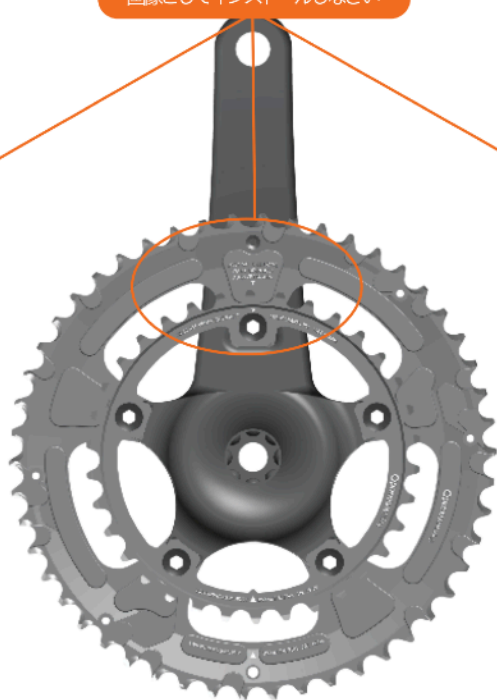

4-ARM WITH HIDDEN 5th MOUNT

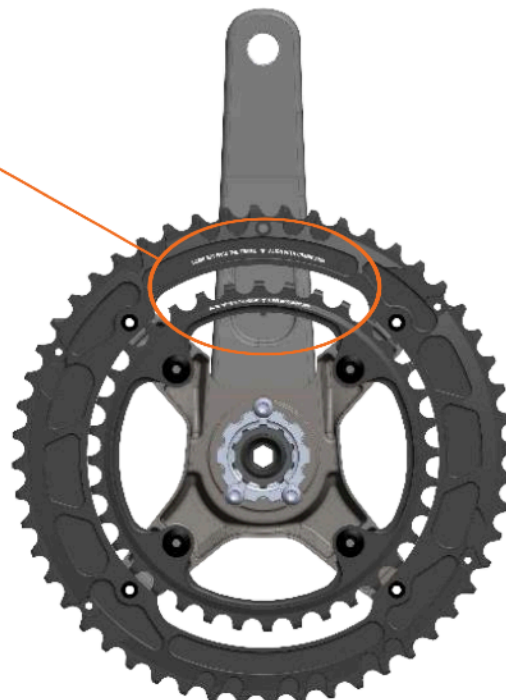

4-ARM PRAXIS X-SPIDER/RINGS



2X CHAIN RING INSTALLATION

The Praxis Works chain rings are matched sets and smooth shifting will not be possible if the chain rings are incorrectly installed. Be sure to install the chain rings in the correct positions as the graphics above show.

CROSS GEARING "SMALL/SMALL"

When the chain is in the position shown at the right, the chain may contact the front chain rings or front derailleur and make noise. If the noise is a problem, shift the chain onto the next-larger rear sprocket or the one after.

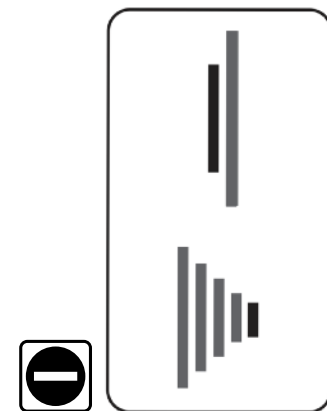

CROSS GEARING

2X ROAD RING SETS CRANK COMPATIBILITY / BCD REFERENCE *Check your crank*

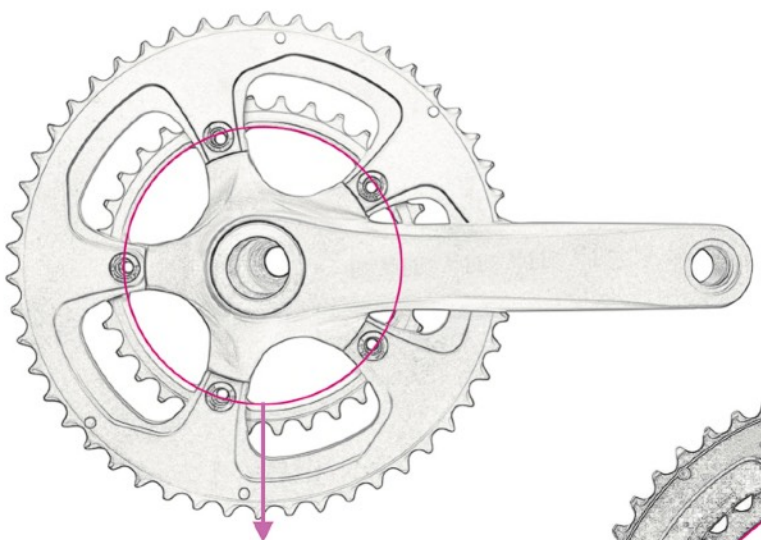

"5-ARM" | 110mm BCD
BOLT CIRCLE DIAMETER

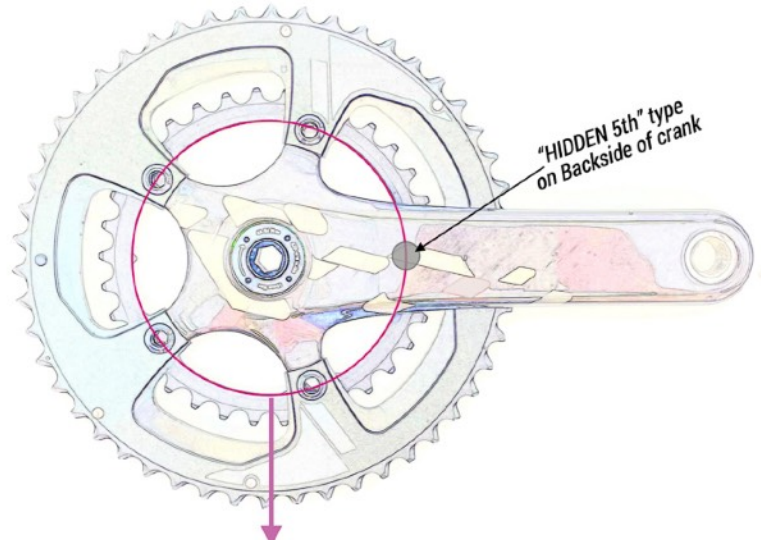

"4-ARM" w/HIDDEN 5th | 110mm BCD
BOLT CIRCLE DIAMETER

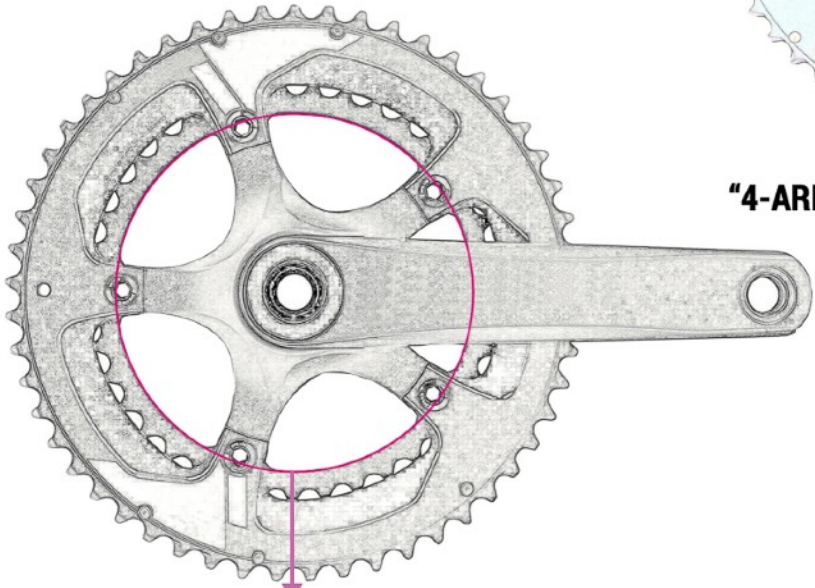

"5-ARM"
130mm BCD | BOLT CIRCLE DIAMETER

REMOVABLE CATCH PIN / PLUG

"BUZZ / BUZZ SPORT / AERO SETS"

SET UP FOR BOTH 5-ARM, OR 4-ARM WITH HIDDEN 5TH MOUNT



INCLUDED WITH 110/130 SETS

CATCH PIN
PLACE BEHIND YOUR CRANK ARM



PLUG PIN
PLACE OPPOSITE SIDE



CATCH PIN
PLACE BEHIND YOUR CRANK ARM



48/32 110BCD SET

"BUZZ / BUZZ SPORT



- Visually inspect your crank mounting tabs!
- **Do NOT install our 48/32 on any crank/spider that does not look like this.**
- Our 110BCD spiders have special tabs required for safe chain clearance/installation. This design allows our 48/32 set to be installed on our Praxis 110BCD cranks in conjunction with our custom ring bolts.
- Our spider tab design is also used by Cane Creek, Bingham and Specialized. *(So visually inspect your spider first!)*