

# PRODUCT INFO

## OFFICE-BAG URBAN QL2.1

Briefcase with QL2.1 system and roll closure



- Carrying handle
- D-Rings for the shoulder strap
- Roll closure with side-release buckle
- Two high-quality „3M Scotchlite“ reflectors
- Padded shoulder strap

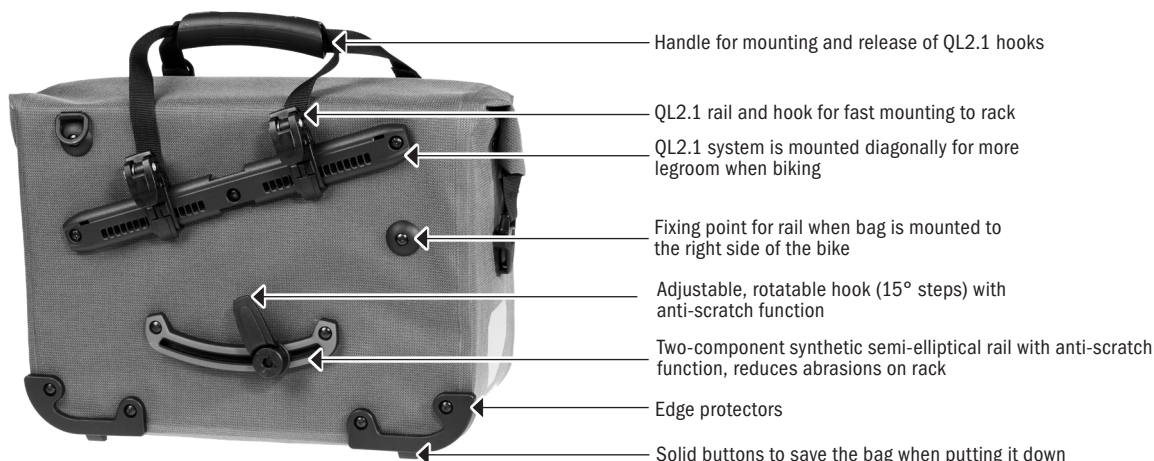

- Handle for mounting and release of QL2.1 hooks
- QL2.1 rail and hook for fast mounting to rack
- QL2.1 system is mounted diagonally for more legroom when biking
- Fixing point for rail when bag is mounted to the right side of the bike
- Adjustable, rotatable hook (15° steps) with anti-scratch function
- Two-component synthetic semi-elliptical rail with anti-scratch function, reduces abrasions on rack
- Edge protectors
- Solid buttons to save the bag when putting it down

height cm/in.	width cm/in.	depth cm/in.	vol. L/cu.in	weight g/oz.	max. capacity kg/lbs.
30/11.8	40/15.7	17/6.7	21/1281	1550/54.7	9/19.8

### SPECIFICATIONS:

- + Waterproof bicycle briefcase with roll closure
- + PU-coated Cordura blend fabric
- + Ideal for biking to the office, city, university etc.
- + QL2.1 system for racks up to 16 mm, compatible with all standard racks up to 16 mm diameter
- + Including reduction pieces for tube diameters 8, 10 and 12 mm with anti-scratch function preventing abrasions on the carrier
- + Thanks to the rotatable mounting the bag can be mounted on the left (standard) or the right side
- + For mounting on the right side: open the outer screws on the bar, remove caps on back side of the bag, rotate the bar and fix the screws, put caps onto previous no longer used holes and tighten screws
- + Lower hook rail made of two-component „hard-soft“ synthetic prevents abrasions on carrier
- + Two high-quality 3M Scotchlite reflectors
- + Reflective ORTLIEB logo on front
- + Big enough for one or two DIN A4 folders, tablet, pens, cell phone, lunch, etc.
- + Inner compartments with zippered pockets
- + Carrying handle and removable padded shoulder strap

**Contents:** Bag comes with padded shoulder strap, 1 pair of reduction pieces in 8, 10 and 12 mm

**Attention:** Remove the shoulder strap or put it inside the bag before cycling

**Optional accessories:** Anti-Theft Device (No. E125), QL2.1 hook 18 mm (E211) and 20 mm (E193)

**Attention:** Maximum load per pannier is 9kg / 20 lbs. We recommend weighing each loaded pannier to confirm that the maximum allowance of the pannier fixation is not exceeded. This practice is advised for both rear and front panniers. CAUTION: The maximum weight capacity of every carrier model is different. Please observe the maximum weight allowance of the carrier fitted to your bicycle. Note: Sometimes the maximum capacity of the panniers fixing system can exceed the maximum capacity of the carrier. DO NOT exceed the maximum capacity of the carrier! Note, that the use of panniers will significantly influence the handling properties of your bicycle.

**ote:** In order to meet standard IP64 (6=dustproof, 4=protected against splash water coming from all directions) the roll closure must be rolled at least 3-4 times.