



M30 MTB CRANK

ALLOY 30/28 SPINDLE DIRECT MOUNT

SAFETY INFORMATION - READ BEFORE RIDE

Since specific tools and experience are necessary for proper installation, it is recommended that the product be installed by a qualified bicycle technician.

Read these crank service instructions carefully before installing it. Loose, worn or damaged parts may cause riding problems and serious injury may occur as a result. If installation and adjustments are not performed correctly, the chain may come off and this may cause you to fall off the bicycle which could result in serious injury. **Read these instructions carefully, and keep them for later use.**

- Be careful not to let your clothing get caught in the chain while riding, otherwise you may fall off the bicycle.
- Check that the chain tension is correct and that the chain is not damaged. If the tension is too weak or the chain is damaged, the chain should be replaced or else it may break and you may fall off the bicycle.
- Use a torque wrench to check the final tightening torque of the main crank bolt. Furthermore, after riding approximately 60 miles (100 km), use a torque wrench to re-check the tightening torques, including the chainring bolts. **Main Crank bolt = Torque 48-52Nm. Chainring Bolts = Torque 8-10Nm.**
- If the frame bottom bracket shell is not parallel, shifting performance will be affected and performance will drop.
- Check that there are no cracks in the crankarms before riding the bicycle. If there are any cracks, the crankarm may break and you may fall off the bicycle.
- Before riding the bicycle, check that there is no play or looseness in the bottom bracket connection. Also, be sure to retighten the crank, chainring bolts, and pedals at periodic intervals.
- If you feel any looseness or 'play' in the bearings, the bottom bracket should be inspected/replaced.
- To ensure the designed performance, only use 10, 11 or 12 sp* chains (*for 12 sp use SRAM Eagle chain only).
- **Parts are not guaranteed against natural wear or deterioration resulting from normal use.**
- For any questions regarding methods of installation, adjustment, maintenance or operation, please contact a professional bicycle dealer or call Praxis Works.
- Praxis Works assumes no responsibility for damages or injury related to improperly installed components.

READ THE STEP BY STEP INSTALLATION INSTRUCTIONS PROVIDED ON THE OTHER SIDE.

WARRANTY

- **Praxis Works products are warrantied to be free from defects in materials or workmanship for two years after original purchase. The warranty is non-transferable and valid to the original purchaser of the product only.**
- Any attempt to modify the product in any way such as drilling, grinding or painting will void the warranty.
- This warranty is not valid for "abused" or neglected products, or products that are damaged by improper installation.
- If a defect is found, our entire liability and your sole remedy shall be, at our option, free repair or replacement of the Praxis product.
- Except as expressly required by law, Praxis Works shall not be held liable for any indirect, special, or consequential damages.

THIS WRITTEN EXPRESS WARRANTY IS IN LIEU OF ALL OTHER WARRANTIES, IMPLIED OR EXPRESSED. This warranty gives you specific legal rights, and you may also have other rights which vary state to state. **For more information on warranty policy and instructions for completing a warranty claim, check out the Full Warranty Policy found at our website. www.praxis-works.com**

M30 MTN Direct Mount Compatibility and Spec

BOTTOM BRACKET	M30 BB REQUIRED - 73mm BSA, 73mm BB30/PF30, BB90/92, T47 73mm
GEARING	30, 32, 34, 36
CRANKARM LENGTH	165, 170, 175

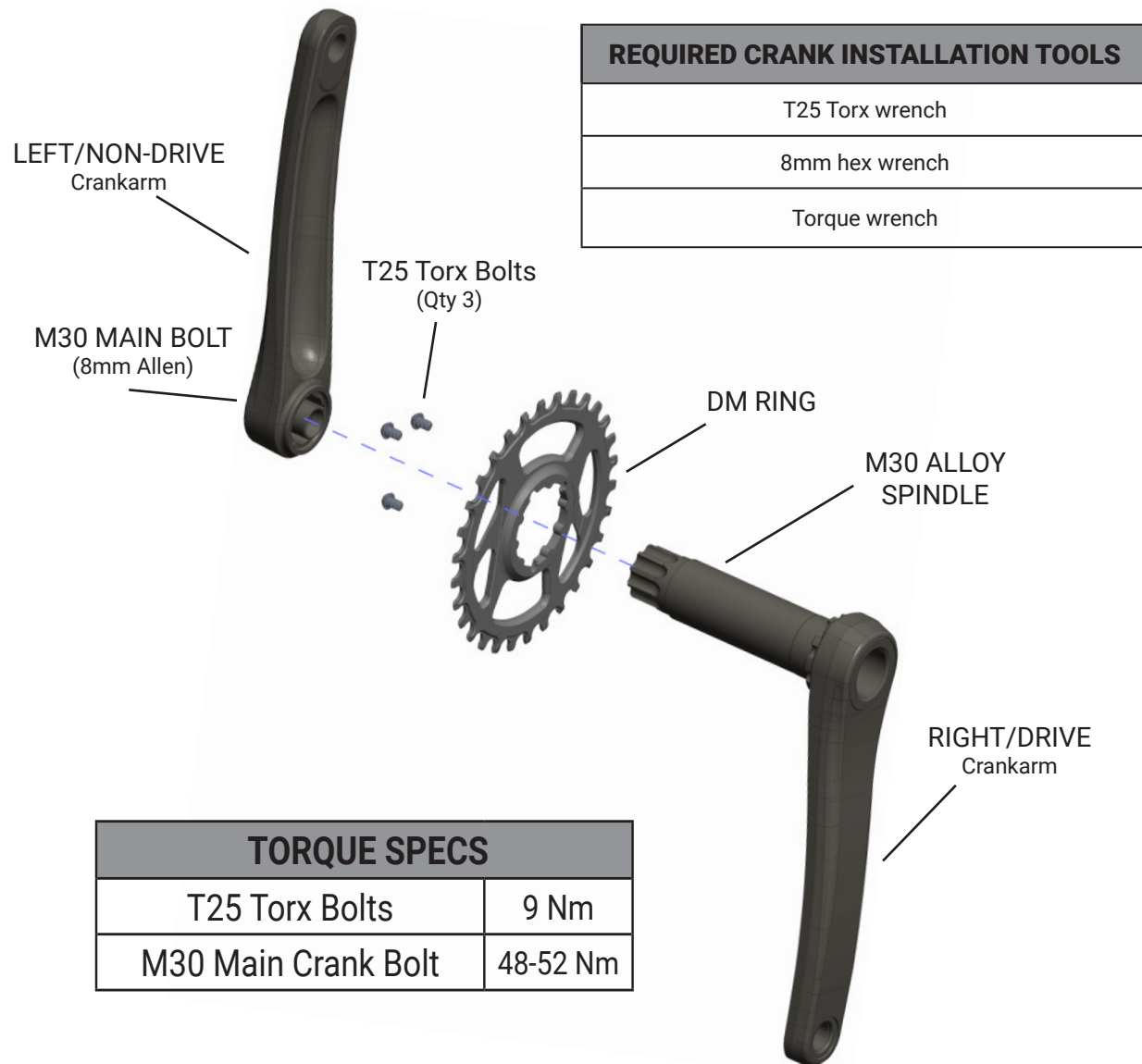

CRANK INSTALLATION

BEFORE YOU START, READ THIS:

- Your Praxis M30 bottom bracket (*sold separately*) must be installed in frame
- Use M30 BB Dust Covers and Wave Washer that came with M30 bottom bracket - *SEE GUIDE ON LAST PAGE!*
- **For M30 bottom bracket instructions:** www.praxiscycles.com/manuals

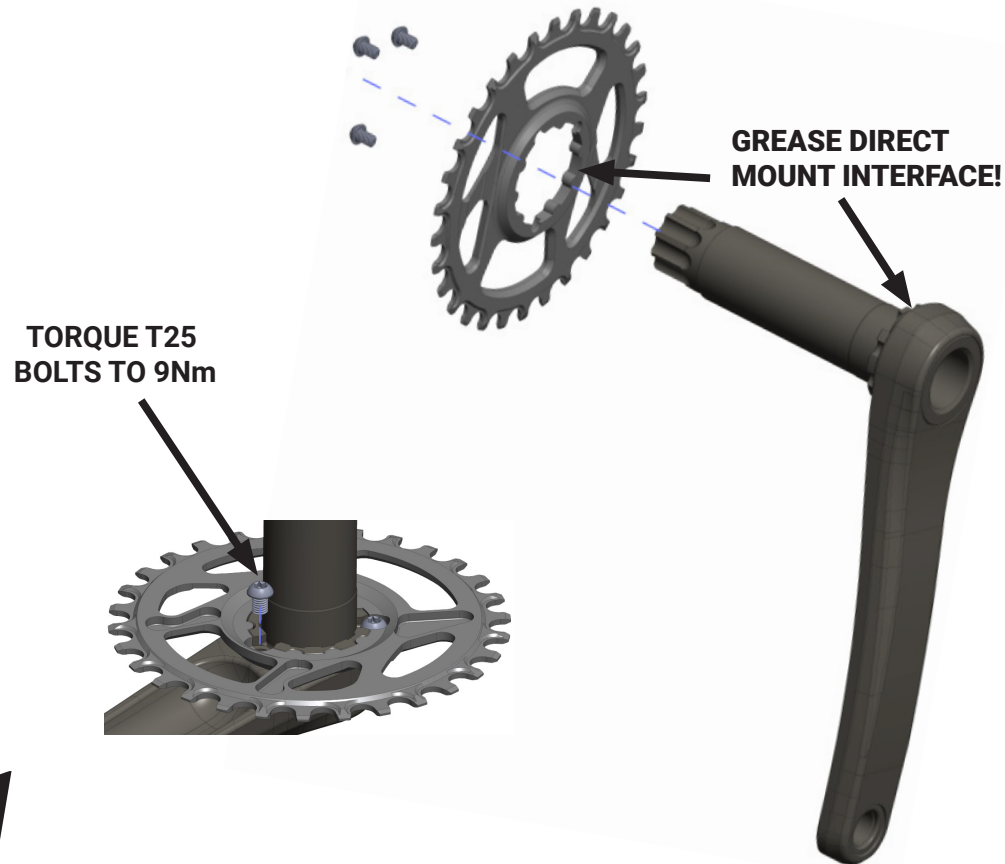

1

1. Grease Direct Mount Ring and arm interface
2. Install ring on drive arm with 3 T-25 bolts
3. Torque bolts to 9Nm

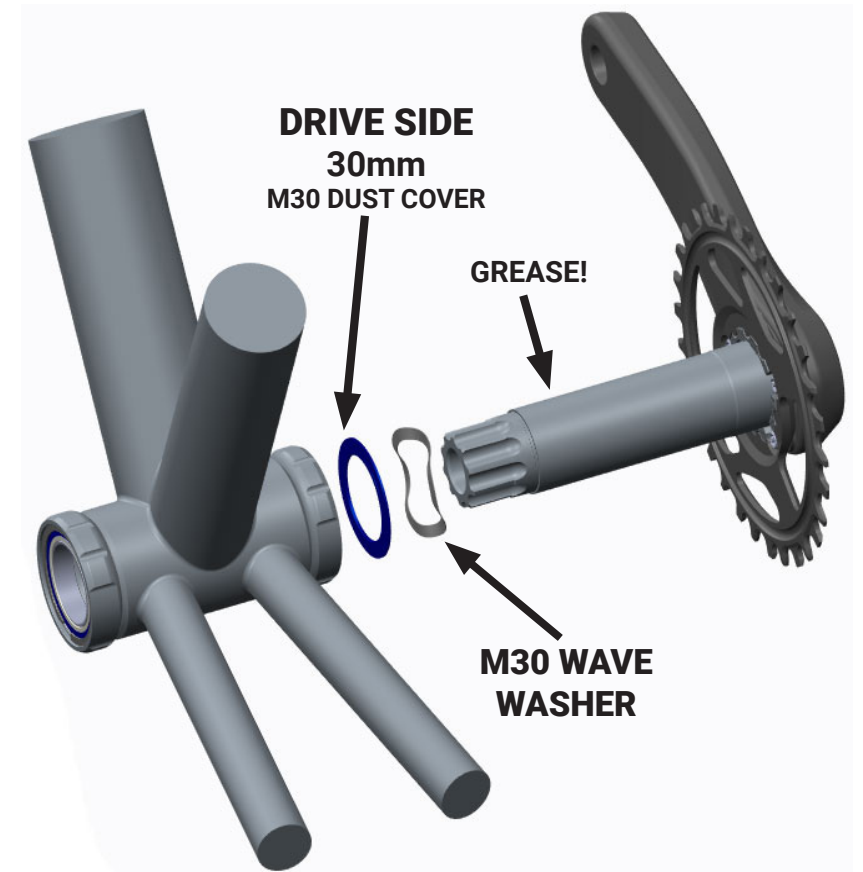

2

1. Grease spindle
2. Slide Wave Washer onto spindle
3. Slide the correct 30mm Dust Cover onto spindle (*see guide*)
4. Verify Dust Cover Praxis logos face ring

Continued next page.....

3

1. Insert crank into Drive Side Cup
2. Push crank fully through bottom bracket
3. Put correct 28mm Non-Drive Side Cover onto spindle (see guide)
4. Verify Dust Cover Praxis logos face outward

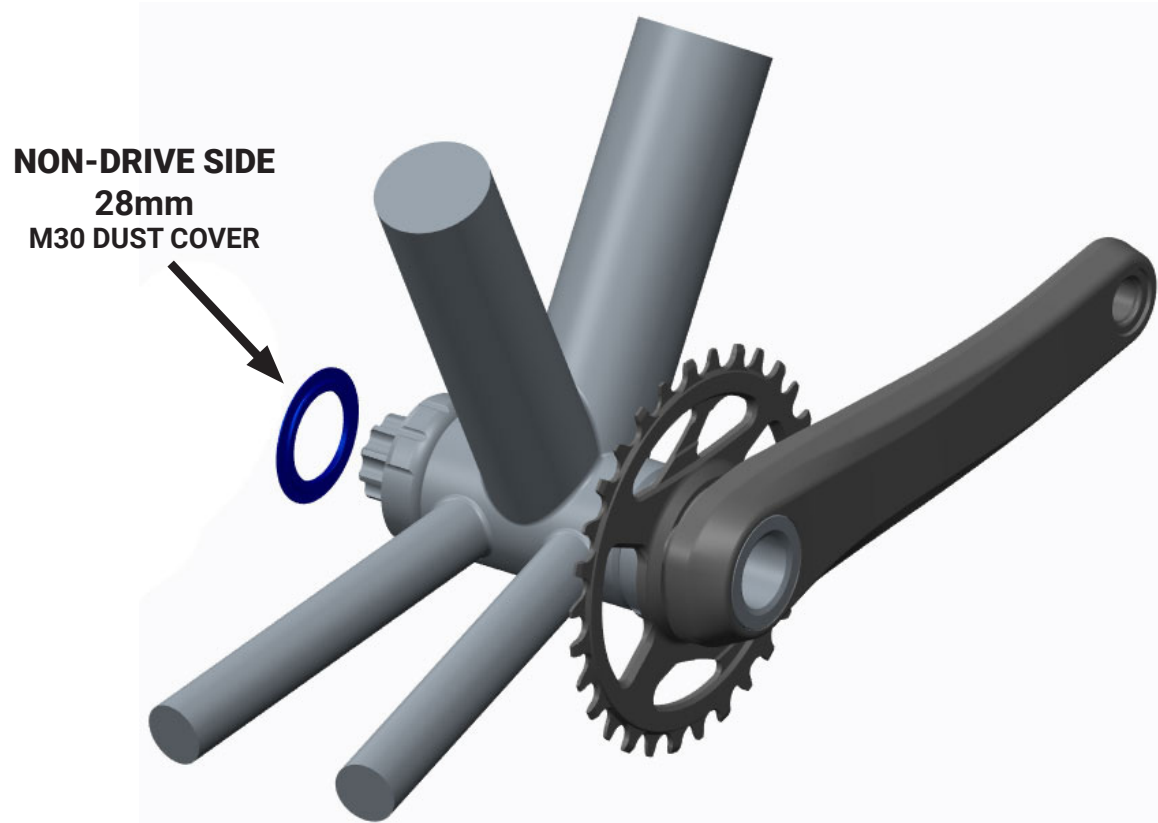

4

1. Install Non-Drive Side arm with 8mm hex wrench
2. Torque arm 8mm bolt to 48-52Nm
3. Verify crank spins freely.
4. Finished

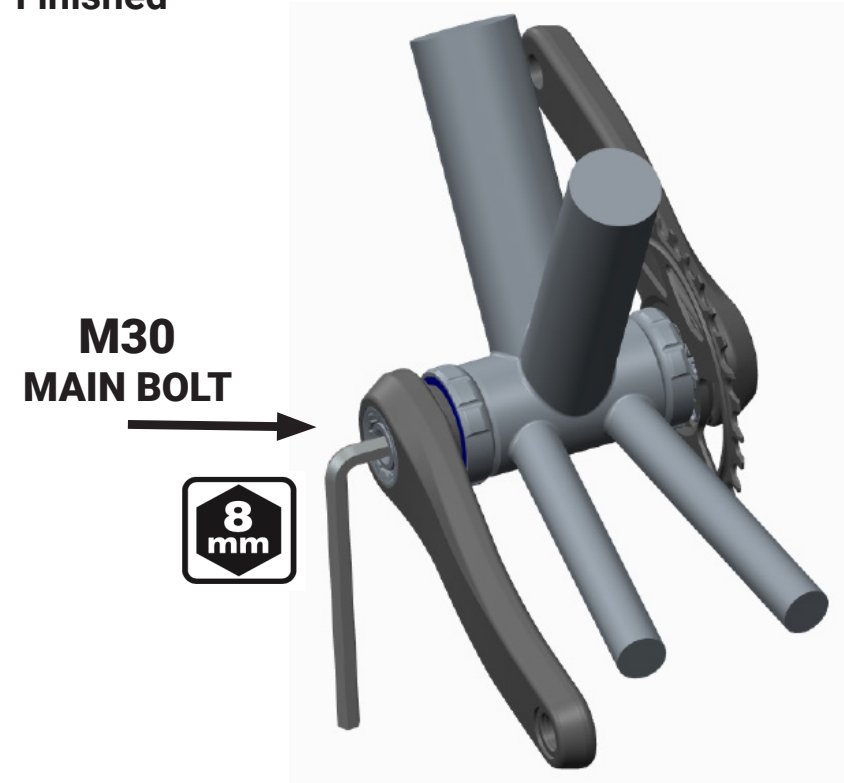

SIMPLE CRANK REMOVAL

ONLY use an **8mm** Allen wrench in the Non-Drive Side crankarm bolt. Turn wrench counterclockwise to loosen the bolt. After it loosens the resistance will increase, which is normal, as it is self-extracting. Keep turning to complete removal of crankarm. Once off, remove the crank from the frame.

Only 1 cover per side!

2mm Cover
ALL CRANKS
(Stepped Cover)

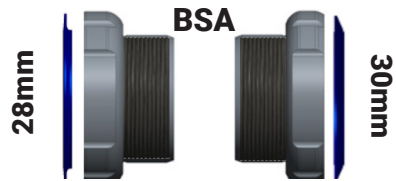

1mm Cover
FOR 3-BOLT GEN1 MTB CRANKS
4mm Cover
FOR 3-BOLT DM GEN2 MTB CRANKS
5mm Cover
FOR NON-DM GEN1 MTB CRANKS

2mm Cover
ALL CRANKS
(Stepped Cover)



1mm Cover
FOR 3-BOLT DM GEN1 MTB CRANKS
4mm Cover
FOR 3-BOLT DM GEN2 MTB CRANKS
5mm Cover
FOR NON-DM GEN1 MTB CRANKS

2mm Cover
ALL CRANKS



1mm Cover
FOR 3-BOLT DM GEN1 MTB CRANKS BB92
2mm Cover
FOR NON-DM MTB CRANKS BB92
FOR 3-BOLT DM GEN1 MTB CRANKS BB90
3mm Cover
FOR 3-BOLT DM GEN2 MTB CRANKS BB92
5mm Cover
FOR NON-DM GEN1 MTB CRANKS BB90
FOR 3-BOLT DM GEN2 MTB CRANKS BB90

2mm Cover
ALL CRANKS
(Stepped Cover)



1mm Cover
FOR 3-BOLT DM GEN1 MTB CRANKS
4mm Cover
FOR 3-BOLT DM GEN2 MTB CRANKS
5mm Cover
FOR NON-DM GEN1 MTB CRANKS

NEW GEN2 PRAXIS MTN CRANKS

ON GEN2 MTN CRANKS - USE THESE RING OFFSETS
FOR THESE SPECIFIC CHAINLINES

6MM OFFSET RING = 49MM CL
3MM OFFSET RING = 52MM CL
0MM OFFSET RING = 55MM CL
-1MM OFFSET RING = 56MM CL

**IDENTIFIER - THIS GUIDE DECAL IS ON BACK
OF ALL GEN2 PRAXIS MTN DRIVE ARMS!**



GEN1 PRAXIS (OLDER) MTN CRANKS

THE OLDER GEN1 MTN CRANKS HAD DIFFERENT SPACING.
USE THESE RING OFFSETS FOR THESE SPECIFIC CHAINLINES

3MM "DMA" OFFSET RING = 49MM CL
0MM "DMB" OFFSET RING = 52MM CL

