

# SuperSix EVO

## Owner's Manual Supplement

 **WARNING**

**READ THIS SUPPLEMENT AND YOUR  
CANNONDALE BICYCLE OWNER'S MANUAL.**

Both contain important safety information.

Keep both for future reference.





# Safety Messages

In this supplement, particularly important information is presented in the following ways:

 <b>WARNING</b>
Indicates a hazardous situation which, if not avoided, may result in death or serious injury.

<b>NOTICE</b>
Indicates special precautions that must be taken to avoid damage.

## Symbols:

Symbol	Name	Description
	Carbon gel/friction paste	Apply carbon gel (friction paste) KF115/
	Anti-Seize Lubricant	Apply Permetex® Anti-Seize Lubricant
	NGLI-2 synthetic grease	Apply NGLI-2 synthetic grease.
	Medium-strength removable thread lock	Apply Loctite® 242 (blue) or equivalent.

**ABOUT ILLUSTRATIONS:** Throughout this manual, all product images, graphics, and figures shown are for illustration purposes only and may not be an exact representation of the product.

---

## Cannondale Supplements

This manual is a “supplement” to your [Cannondale Bicycle Owner’s Manual](#).

This supplement provides additional and important model specific safety, maintenance, and technical information. It may be one of several important manuals/supplements for your bike; obtain and read all of them.

Please contact your Authorized Cannondale Dealer immediately if you need a manual or supplement or have a question about your bike. You may also contact us using the appropriate country/region/location information.

You can download Adobe Acrobat PDF versions of any manual/supplement from our website: <http://www.cannondale.com>.

## Contacting Cannondale

### Cannondale USA

1 Cannondale Way  
Wilton, CT 06897, USA  
1-800-726-BIKE (2453)

### Cannondale Europe

Geeresteinselaan 57  
3931JB Woudenberg  
The Netherlands

### International Distributors

Consult our website to identify the appropriate Cannondale Dealer for your region.

## CONTENTS

<b>Safety Information</b> .....	<b>4-7</b>
<b>Technical Information</b> .....	<b>8-21</b>
<b>Replacement Parts</b> .....	<b>22-25</b>
<b>Notes</b> .....	<b>26-28</b>

## Your Cannondale Dealer

To make sure your bike is serviced and maintained correctly, and that you protect applicable warranties, please coordinate all service and maintenance through your Authorized Cannondale Dealer.

### NOTICE

Unauthorized service, maintenance, or repair parts can result in serious damage and void your warranty.

## SAFETY INFORMATION

### Important Composites Message

#### WARNING

Your bike (frame and components) is made from composite materials also known as “carbon fiber.”

All riders must understand a fundamental reality of composites. Composite materials constructed of carbon fibers are strong and light, but when crashed or overloaded, carbon fibers do not bend, they break.

For your safety, as you own and use the bike, you must follow proper service, maintenance, and inspection of all the composites (frame, stem, fork, handlebar, seat post, etc.) Ask your Cannondale Dealer for help.

We urge you to read PART II, Section D. “Inspect For Safety” in your [Cannondale Bicycle Owner’s Manual](#) BEFORE you ride.

**You can be severely injured, paralyzed or killed in an accident if you ignore this warning.**

### Inspection & Crash Damage Of Carbon Frames/Forks

#### WARNING

##### **After A Crash Or Impact:**

Inspect frame carefully for damage. See PART II, Section D. Inspect For Safety in your [Cannondale Bicycle Owner’s Manual](#).

Do not ride your bike if you see any sign of damage, such as broken, splintered, or delaminated carbon fiber.

##### **Any of the following may indicate a delamination or damage:**

- An unusual or strange feel to the frame
- Carbon which has a soft feel or altered shape
- Creaking or other unexplained noises,
- Visible cracks, a white or milky color present in carbon fiber section

**Continuing to ride a damaged frame increases the chances of frame failure, with the possibility of injury or death of the rider.**

## Intended Use

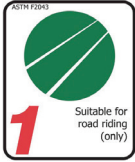

The intended use of all models is  
ASTM CONDITION 1,  
High-Performance  
Road.

### WARNING

Please read your Cannondale Bicycle Owner's Manual for more information about Intended Use and Conditions 1-5.

## Servicing

### WARNING

**This supplement may include procedures beyond the scope of general mechanical aptitude.**

Special tools, skills, and knowledge may be required. Improper mechanical work increases the risk of an accident. Any bicycle accident has risk of serious injury, paralysis, or death.

**To minimize risk we strongly recommend that owners always have mechanical work done by an Authorized Cannondale Dealer.**

## Disc Brakes on Road Bikes

### WARNING

Relative to conventional rim brakes, disc brakes are less affected by water, do not wear or heat the rims and therefore are more consistent. Disc brakes also may be more powerful.

#### To minimize risk of injury or accidents:

- Understand that road bikes have a relatively small tire contact patch (part of the tire that touches the road). In order to apply the brakes safely and effectively, you may need more or less braking force in different situations. You need to take into account various road and weather conditions that can affect traction.
- Disc brakes are excellent, but not some kind of magic. Take some time riding your new disc brake road bike in lower risk circumstances to get used to the feel and performance of the disc brakes and tires.

**You can be severely injured, paralyzed or killed in an accident if you ignore this message.**

## Using a Trainer

Follow the trainer manufacturer's instructions for required adapters. Use caution with carbon frames or forks, as carbon is soft and wears quickly if there's movement. For frequent trainer use, consider an old bike to avoid sweat corrosion and component wear, as weight isn't a factor. Consult your dealer for help choosing and using the right trainer.

### **NOTICE**

TRAINERS - Improperly mounting a bike in a trainer, or using one that is not compatible with your particular bike frame can cause serious damage.

This kind of damage is not covered by the Cannondale Limited Warranty.

## Water Bottles

Side impacts to a water bottle or cage can damage threaded inserts due to leverage on a small area. During a crash, prioritize safety over protecting inserts. When storing or transporting your bike, prevent impacts to the bottle by removing it and the cage. Regularly check and tighten cage bolts to avoid a loose cage, which can damage or dislodge inserts. If an insert is loose or damaged, consult your Cannondale Dealer for repair or replacement using a special tool, provided the frame is undamaged.

### **NOTICE**

An impact, crash, or loose bottle cage can result in damage to your frame. This kind of damage is not covered by the Cannondale Limited Warranty.

## Building Up A Frameset

Before building a frameset, consult your Cannondale Dealer and component manufacturers about your riding style, ability, weight, and maintenance preferences. Ensure components are compatible with your bike, weight, and riding style. Lighter components offer higher performance but shorter lifespans, requiring more frequent inspections. Heavier or aggressive riders should choose heavy-duty components. Follow all component manufacturer warnings and instructions.

## Maximum Tire Compatibility

This model supports tires up to 32mm wide, requiring at least 4mm clearance between the inflated tire and frame, fork, fender (including hardware), and drivetrain at all wheel rotation points. Less than 4mm clearance may cause interference and damage.

### NOTICE

Measure actual tire width and clearances with the tire inflated to the lower maximum pressure specified on the rim or tire to confirm 4mm of available clearance for any tire.

## Tightening Torques

Proper fastener torques (bolts, screws, nuts) are vital for your bike's safety, durability, and performance. Have your dealer torque fasteners with a torque wrench, or if you do it yourself, always use one.

### Find Tightening Torque Information :

Due to the variety of bicycle models and components, a published list of tightening torques would quickly become outdated.

Many fasteners require thread-locking adhesive like Loctite®. It is important to renew the thread lock application as needed or following repeated removal/reinstallations of a fastener.

### To find the correct torque and thread lock use, check:

- On-product torque markings.
- Component manufacturer's instructions included with your bike.
- Torque specs on component manufacturers' websites.
- With your dealer, who has access to current data and expertise in proper fastener torques.

## TECHNICAL INFORMATION

### Specifications

Item	Specification
Head Tube	UPR: 1-1/8in, LWR: 1-1/4in
Headset	IS42/28.6 Top IS47/33 Bottom Integrated 45 degree crown race
Bottom Bracket: Type/Width	BSA threaded/68mm (sleeve required, pg 13.)
Front Derailleur	Braze-on
Seat Post: /Binder	0mm Offset: K2601600/K2604500
	15mm Offset: K2601615/K2604515
	Internal Seatbinder: K26086
▲ Min. Seat Post Insert	65mm
Max. Seat Post Insert	44cm: 109mm 48cm: 132mm 50cm:141mm 52cm: 151mm 54cm: 151mm 56cm: 154mm 58cm: 155mm 61cm: 179mm
Tire Size x Max. Tire Width	700c x 32mm (measured)
Brakes: Mount Type / Min./Max. Rotor Dia.	FT: Flat Mount/140mm/160mm RR: Flat Mount/140mm/160mm
Axles: Type/Length	FT: 100×12, M12×1.0P, 118mm Overall Length RR: 142×12, M12.1.0P, 163mm Overall Length
Fork Offset	Size 44cm-54cm: 55mm, Size 56cm-61cm: 45mm
▲ Intended Use	ASTM Condition 1: High-Performance Road
▲ Max. Weight Limit: Total (Rider+All Equipment)	285lbs/129kg

### Serial Number

Use the 7-digit serial number label (1) located on the bottom bracket to register your bike.

**Product Registration**

[www.cannondale.com](http://www.cannondale.com)

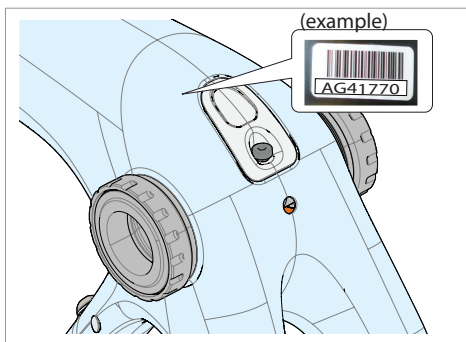

## Geometry

Dimensions = centimeter

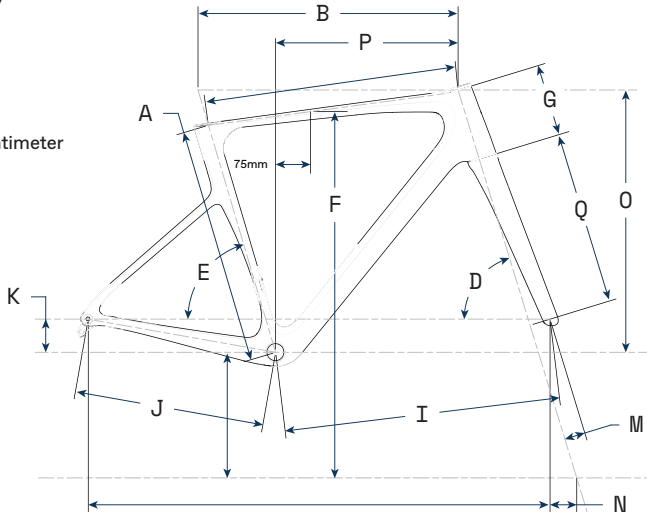

	Size	44	48	50	52	54	56	58	61	
∅	Wheel Size	700c								
A	Seat Tube Length	40.0	42.9	44.8	46.7	49.0	51.0	53.2	57.0	
B	Top Tube Horizontal	51.0	52.2	52.9	53.6	54.4	56.0	57.7	60.0	
C	Top Tube Actual	49.2	50.3	51.1	51.9	52.7	54.3	55.9	58.2	
D	Head Tube Angle	70.9°	71.2°				73.0°			
E	Seat Tube Angle Effective	74.5°	74.0°				73.5°	73.0°	72.5°	
F	Standover	69.4	71.7	73.3	75.2	77.0	79.0	81.2	84.6	
G	Head Tube Length	8.9	10.1	11.4	13.0	14.3	15.4	17.8	20.9	
H	Wheelbase	98.0	98.5	99.3	100.2	101.0	99.5	100.7	102.4	
I	Front Center	58.2	58.6	59.4	60.2	61.1	59.5	60.7	62.4	
J	Chain Stay Length	41.0								
K	Bottom Bracket Drop	7.4				7.2			6.9	
L	Bottom Bracket Height	26.9	26.9	26.9	27.1	27.1	27.1	27.4	27.4	
M	Fork Rake	5.5					4.5			
N	Trail	6.0	5.8							
O	Stack	49.5	50.8	52.0	53.2	54.5	56.5	58.5	61.5	
P	Reach	37.3	37.6	37.9	38.3	38.7	39.3	39.8	40.6	
Q	Axle to Crown	37.6								

## Seat Post

### To remove seat post:

1. Turn the binder screw with a 4mm hex key counter-clockwise to loosen the clamp. When clamp is loose, simply lift the seat post up out of the seat tube.

### To install the seat post:

1. Remove the binder clamp, clean it and the frame pocket, then apply fresh grease to the surface that will fit against the frame, as shown on the next page.

**Apply grease to the binder bolt threads when re-installing the part into the frame. The application of grease on the threads reduces thread friction and results in better-applied torque.**

Reinstall the binder clamp into the frame pocket.

2. Apply fresh carbon friction paste to the inserted section of the seat post and inside the seat tube, including the surface of the binder clamp which contacts the seat post.
3. Insert the seat post into the frame.
4. Set the saddle height, observing the minimum insert and within the limits of the maximum insert for the frame and tighten the clamp screw to 6 Nm.
5. Lower the rubber cover to the frame.

### To adjust height:

1. Insert a 4mm hex into the clamp screw.
2. Loosen the binder screw sufficiently to move the seat post up or down in the seat tube.
3. Set the seat post position.
4. Tighten the binder clamp screw to 6 Nm.

### To remove binder:

1. Remove the seat post.
2. Using a 4mm hex key, turn the screw clockwise (tightening it) until the binder clamp disengages from the threaded base and can be lifted up out of the seat tube. Take care not to let the binder clamp fall into the seat tube.

### Maintenance

Periodically remove the seat post and the binder clamp assembly to clean, to inspect for damage, and to renew the application of grease and of carbon gel.

#### NOTICE

Do not exceed the specified torque.

Do not use any spray cleaners or solvents to clean.

Do not adjust a seat post so it is bottomed out in the frame.

For more information about carbon fiber seat posts, see also “Care and Maintenance of Carbon Fiber Seat Posts” in your Cannondale Bicycle Owner’s Manual.

**IMPORTANT:** Tighten the seat binder to 6Nm. Gently move the seat post to settle the internal wedge in the frame pocket and retighten to 6Nm. Repeat this process three times.

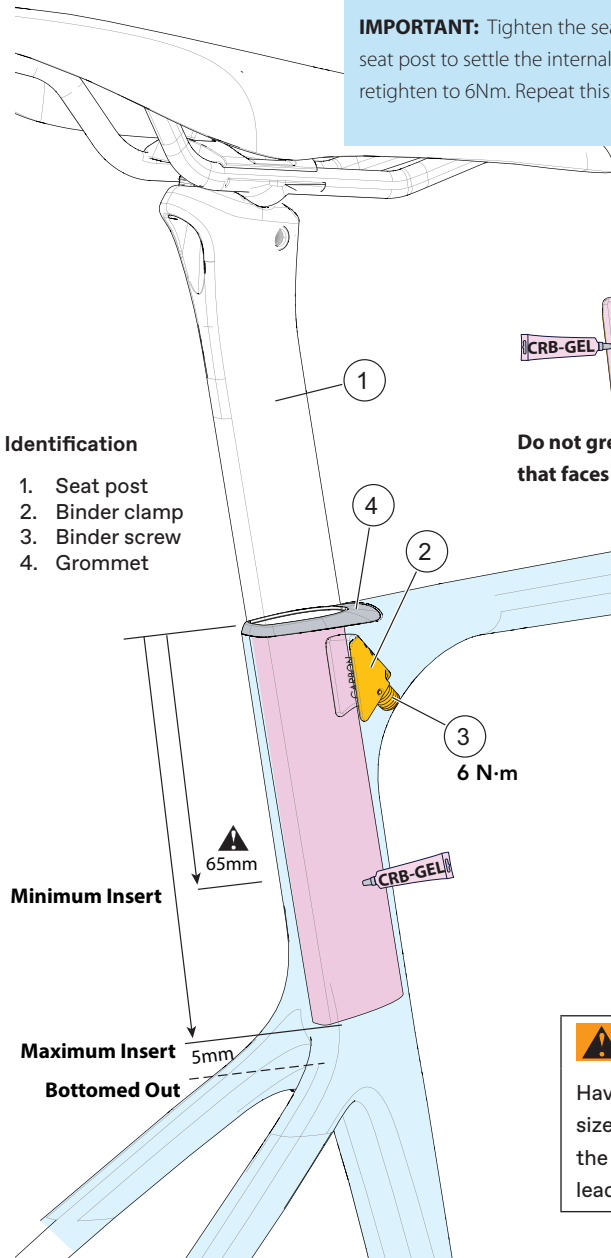

**Identification**

- 1. Seat post
- 2. Binder clamp
- 3. Binder screw
- 4. Grommet

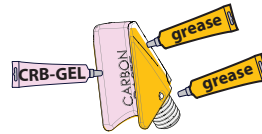

**Do not grease the surface of the binder that faces the seat post.**

6 N·m

Bike Size (cm)	Maximum Insert (mm)
44	109
48	132
50	141
52	151
54	151
56	154
58	155
61	179

**WARNING**

Have a professional bike mechanic size the seat post. Incorrectly cutting the seat post can result in damage leading to an accident.

## SEAT POST CUTTING INSTRUCTIONS - (Professional Mechanic Only)

### Overview

Shortening the seatpost may be required if saddle height cannot be achieved within the allowable insert range or when preparing a new uncut full-length post.

### Cutting Procedure

#### 1. Confirm the frame-specific Insert Requirements

Refer to frame Specifications table in this manual for :

- Verifying **minimum insert distance**.
- Verifying **maximum allowable insert** for the frame size.
- Cut only if the uncut post exceeds the usable range.

#### 2. Mark the Cut Line

- Insert post until it stops, then raise 5 mm to ensure it is not bottomed out.
- Measure and mark material to be removed.
- Match any original angled cut at bottom of the post for proper fit.

#### 3. Cut the Seat Post

- Use a carbon-specific cutting guide and carbon saw blade.
- Make a smooth, controlled cut along the marked angle.
- Lightly sand the edge to remove burrs.
- Do not score, scratch, or damage the carbon surface.

#### 4. Re-Mark the Minimum Insert Line

- Measure from the new end and reapply the minimum insert line with a permanent marker.
- Do not engrave or etch the post.

#### 5. Inspect Before Installation

- Check for cracks, splintering, or surface damage.
- Do not install if any damage is present.

#### Important Notes

- Never install a post that bottoms out inside the frame.
- Never exceed torque specifications.
- Always apply carbon friction paste to the inserted section.

## Saddle Clamp Assembly

**IMPORTANT:**

Titanium and steel fasteners of the seatpost saddle clamp assembly must receive different lubrication on the threads.

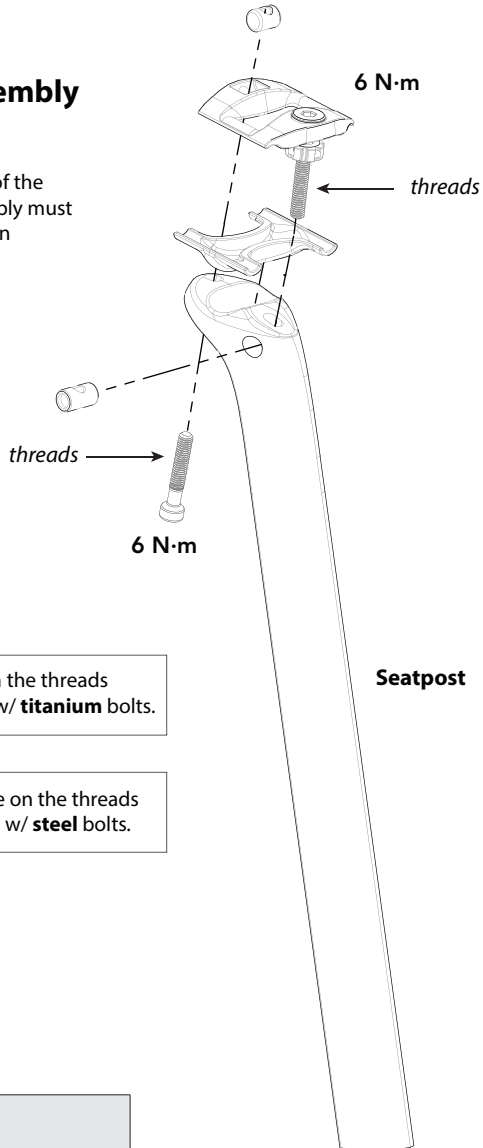

 Apply anti-sieze on the threads when assembling w/ **titanium** bolts.

 Apply light grease on the threads when assembling w/ **steel** bolts.

**NOTICE**  
Apply anti-sieze or grease as directed.

## Shimano Di2 Battery Holder

### Assembly Instructions:

1. Clip in (opt1) or Slide in (opt2) the Di2 battery (1) into the battery holder lower shell (2).
2. Check if battery seats properly: Battery should be seated firmly against the stop (a). The assembly will not close properly if the battery is not seated properly..
3. Position the upper shell (3) on the hinge (b) of the lower shell (2)
4. Rotate the upper shell downwards until the upper shell latches (c) click into the lower shell openings (d).
5. Connect the holder and battery to the frame wiring and insert into the frame opening (e) at the bottom bracket shell.
6. Secure the battery and holder in the frame with the screw (4) and tighten to 0.5 Nm.

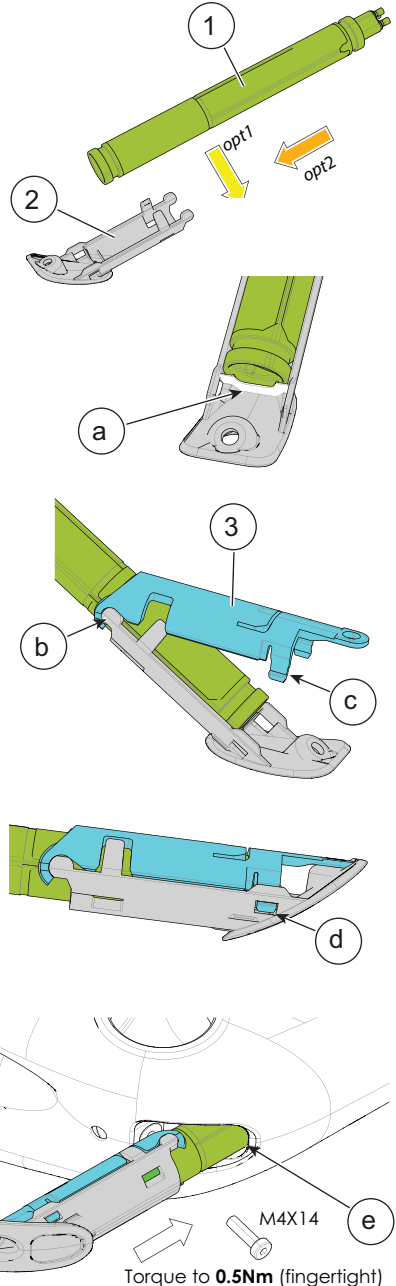

## Routing - Overview

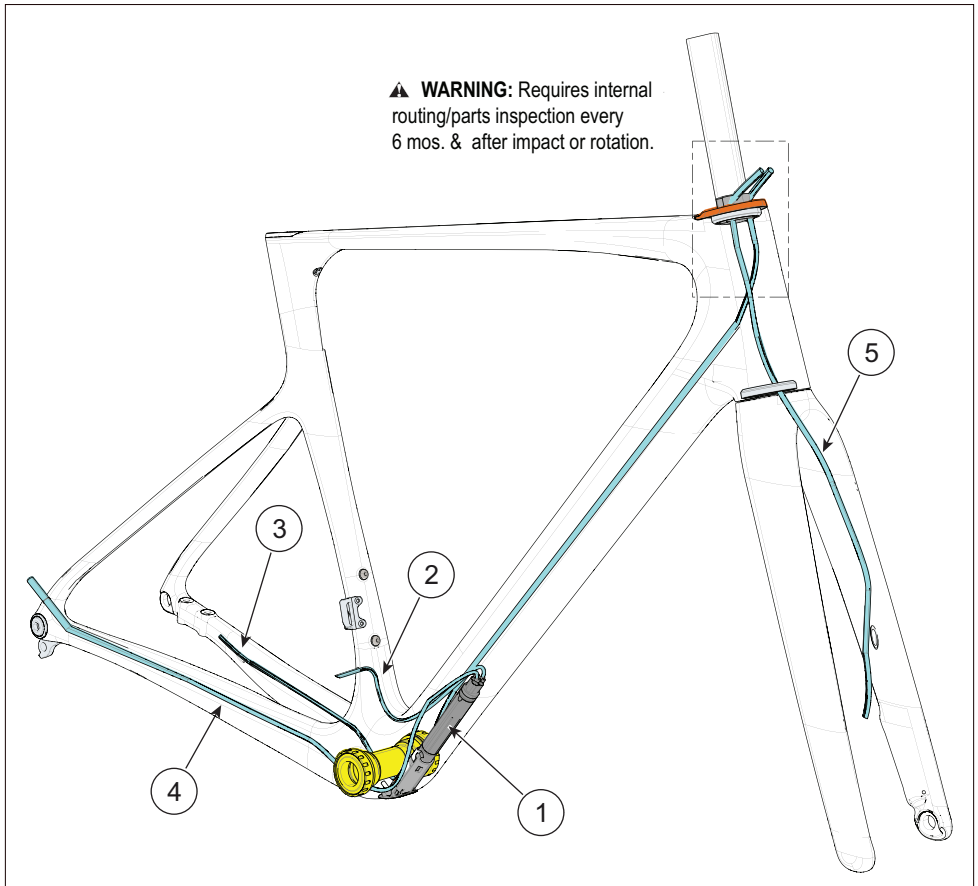

### NOTICE

Hose lengths must be carefully selected. Avoid both too long and too short. Incorrect lengths can limit steering angle and damage hoses.

### Identification

- |                          |                         |
|--------------------------|-------------------------|
| 1. Di2 battery           | 4. Rear derailleur line |
| 2. Front derailleur wire | 5. Front brake line     |
| 3. Rear brake line       |                         |

## Routing - Bottom Bracket Sleeve

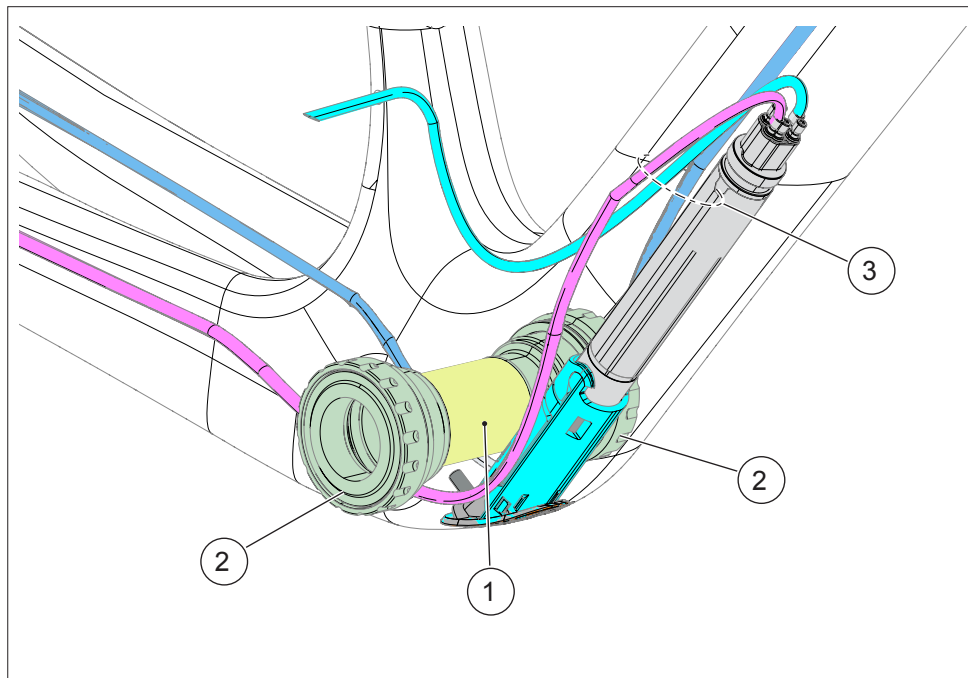

### Identification

1. Bottom bracket sleeve
  2. Bottom bracket cup
  3. Routed wires/cables
- Position the cables and wires around the bottom bracket sleeve insert to ensure smooth operation and a clear pathway.

### **WARNING**

This frame requires a bottom bracket having an integrated sleeve to prevent spindle contact with internal wires or hoses. Do not remove or omit the sleeve during assembly or service.

## Delta Fork Headset Compression Assembly

The SuperSix EVO 5 utilizes a delta fork, a fork with a triangular steerer. Only a delta fork headset compression assembly can be used.

### Filler Pieces

- The Conceal Stem uses the assembly with fillers that are black in color. Cannondale SystemBar fillers are pink in color.
- The foot of the filler pieces point down and are positioned at the rear as shown in the following example illustrations.

### Sizing And Cutting A Delta Fork

The Cannondale Service Instructions: Delta Fork Headset Compression Assembly define the correct method for cutting and preparing the delta fork. See QR code next page.

### Locating the Split Ring Opening

The opening of the split ring should be positioned in the bearing so that it is aligned toward the back of the bike as shown. Do not locate the split ring opening over the side of the delta shape where the internal routing passes.

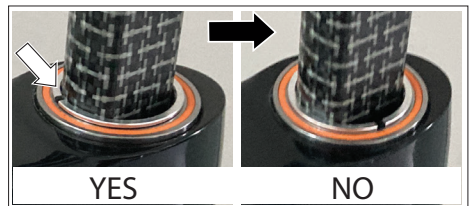

### WARNING

The headset, stem, handlebar spacers, and compression assembly of your bike are parts of a system designed to work together. It is important to your safety that you do not alter, remove or omit parts, or assemble the system incorrectly.

This manual does not include instructions for servicing. This is why you should have work on the system performed by a professional bicycle mechanic with the experience, tools, and information to complete any needed service.

Part Number	Description
K35051	Conceal Delta Expander Plug
K3507310	Conceal Delta Filler Pieces L+R BLK

**C1 Conceal Stem**

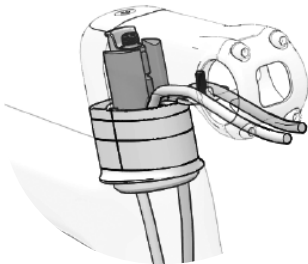
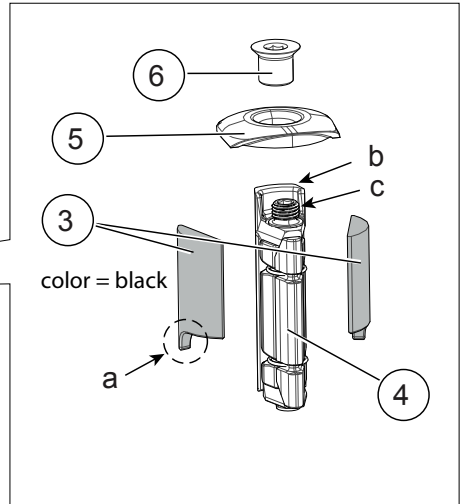
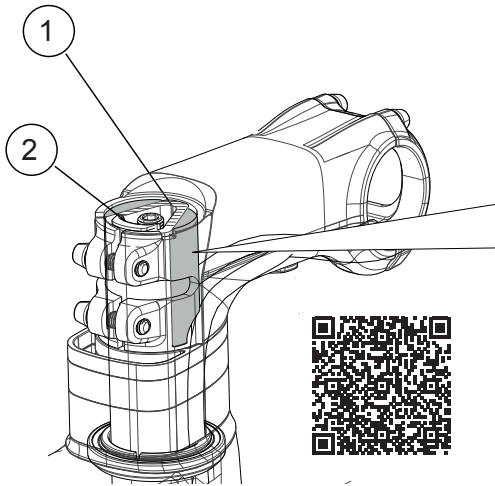

**Maintenance/Inspection Required**

**⚠ WARNING**

This system requires a careful inspection of the internal routing, headset components, and the frame inspection for wear every 6 mos. & for damage after impact or a rotation (spin) of the handlebar. To identify any potential damage, the inspection should be performed by a professional bicycle mechanic under the disassembled condition of the headset and fork.

**Identification**

- |                        |                     |                         |
|------------------------|---------------------|-------------------------|
| 1. Delta fork steerer  | 5. Conceal top cap  | b. Expander lip         |
| 2. Delta expander      | 6. Conceal cap bolt | c. Expander fixing bolt |
| 3. Delta Filler pieces |                     |                         |
| 4. Expander bolt       | a. Filler foot      |                         |

## C1 Conceal Stem

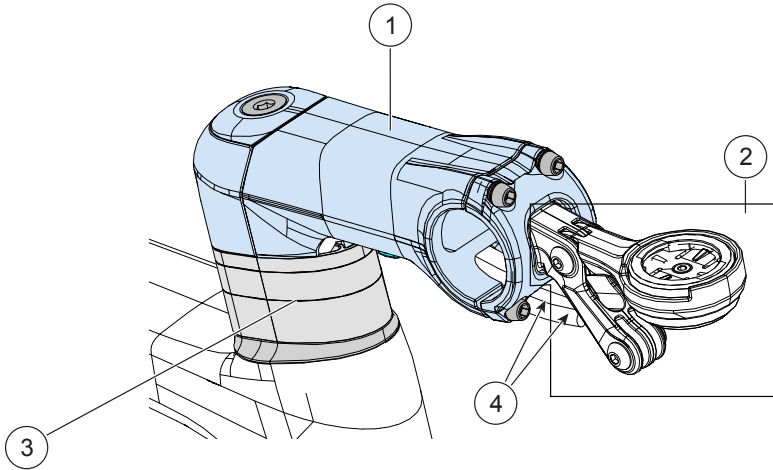

### Identification

1. C1 Conceal stem
2. C1 Conceal accessory mount
3. Spacers
4. Brake hoses
5. Delta fork head-set compression assembly
6. Delta filler pieces

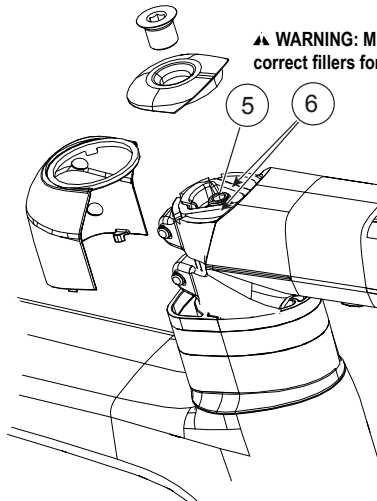

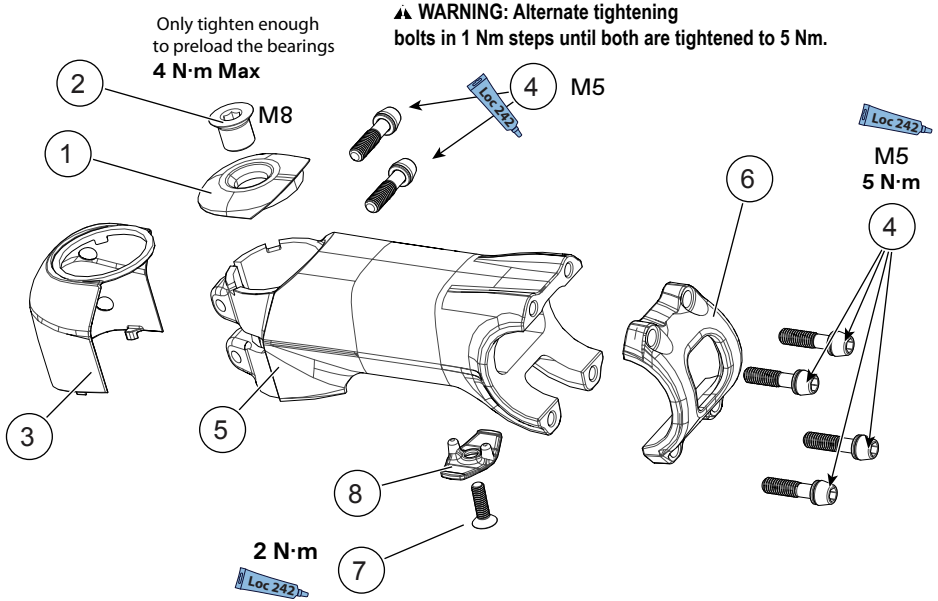

## C1 Conceal EX Stem Mount

### Identification

1. Top cap
2. Compression nut
3. Cover
4. Faceplate clamp bolts
5. Stem body
6. Face plate
7. Screw M4 × 12
8. Cable clip
9. Friction flange
10. Computer Mount
11. Bolt M5 × 18
12. Quarter turn mount, Garmin
13. Quarter turn mount, Wahoo
14. Base puck
15. Screw M3 × 8
16. Light mount
17. Hammerhead Adapter

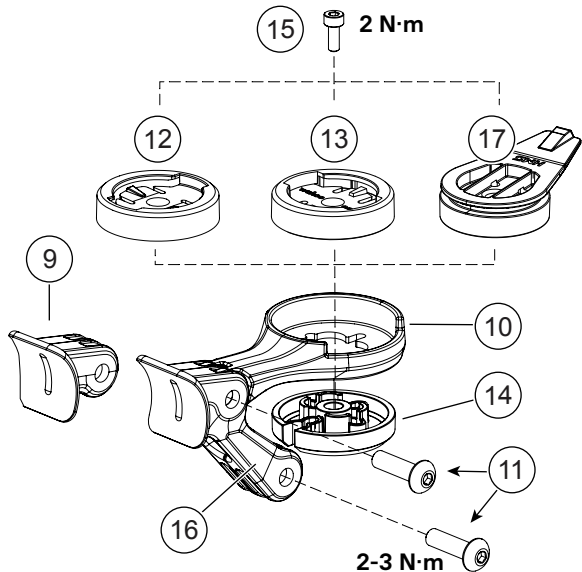

## Universal Derailleur Hanger (UDH)

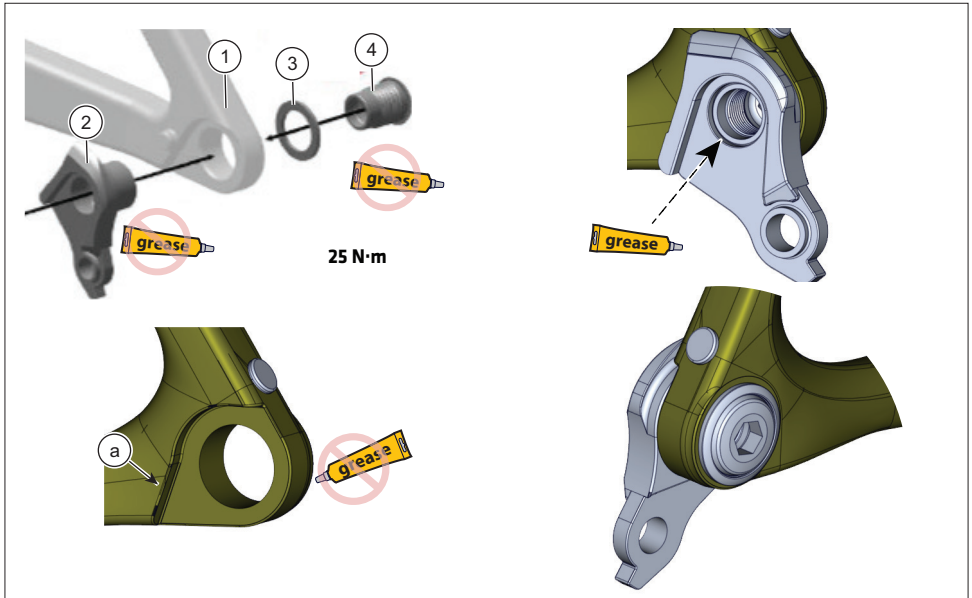

### Identification

1. Right dropout
2. Hanger
3. Hanger washer
4. Hanger bolt
- a. rotation stop

### Replacement

Before installing a new or replacement hanger, be sure to clean any dirt or debris on the dropout with a nylon brush (old toothbrush). Inspect the area for any damage, especially after a crash or impact. Take corrective action when required. Use a good-quality torque wrench and tighten to the specified torque.

### NOTICE

Follow the manufacturer instructions when mounting the universal derailleur hanger to the frame. SRAM - <https://www.sram.com/en/sram/models/ac-drhg-mtb-a1>

## REPLACEMENT PARTS

### Frame Parts

ID	Part Number	Description
A1	Universal Derailleur Hanger	SRAM P/N: 00.7918.093.000
A2	K33025	Derailleur Hanger TA DM UDH 093 - Shimano Direct Mount
B	K33006	S6 EVO5 FD Hanger
C	K26086	S6 EVO5 Internal Seatbinder Sandblasted
D	K35006	S6 EVO5 Dust Cover
E	K26006	S6 EVO5 Seatpost Grommet
F	K34026	S6 EVO5 Wireless BB Plug
G	K18016	S6 EVO5 Di2 BB Battery Mount
H	K32280	Dropout Di2 and Wireless Plugs 5.5mm
I	K35051	Conceal/Aftermarket Delta Expander Plug
J	K28042	Delta Preload Stem Spacer Kit
K	K8302410	Syntace TA 100×12 118mm M12×1.0P BLK
	K8300410	Syntace TA 100×12 118mm M12×1.0P SL RAW
L	K8303410	Syntace TA 142×12 163mm M12×1.0P BLK
	K8301410	Syntace TA 142×12 163mm M12×1.0P SL RAW
M	K35023	S6 Delta 1-1/8 - 1-1/4 Int Hdset
N	K2601600	C1 Aero 40 v2 Seatpost 365mm 0 O/set
	K2601615	C1 Aero 40 v2 Seatpost 365mm <b>15 O/Set</b>
O	K2604500	C1 Aero 40 v2 Seatpost Ti 365mm 0 O/Set
	K2604515	C1 Aero 40 v2 Seatpost Ti 365mm <b>15 O/Set</b>
P	K26026	C1 Aero Rail Clamp w/ <b>Steel Hardware</b>
Q	K26036	C1 Aero 5 Rail Clamp w/ <b>Ti Hardware</b>
R	K34232	S6 Evo CS Protector
S	K32094	4mm Blind Grommet Qty10
--	K28062	Conceal/SystemBar Spacer Kit
--	K18086	C1 Conceal EX Accessory Mount

"--" - Item not pictured

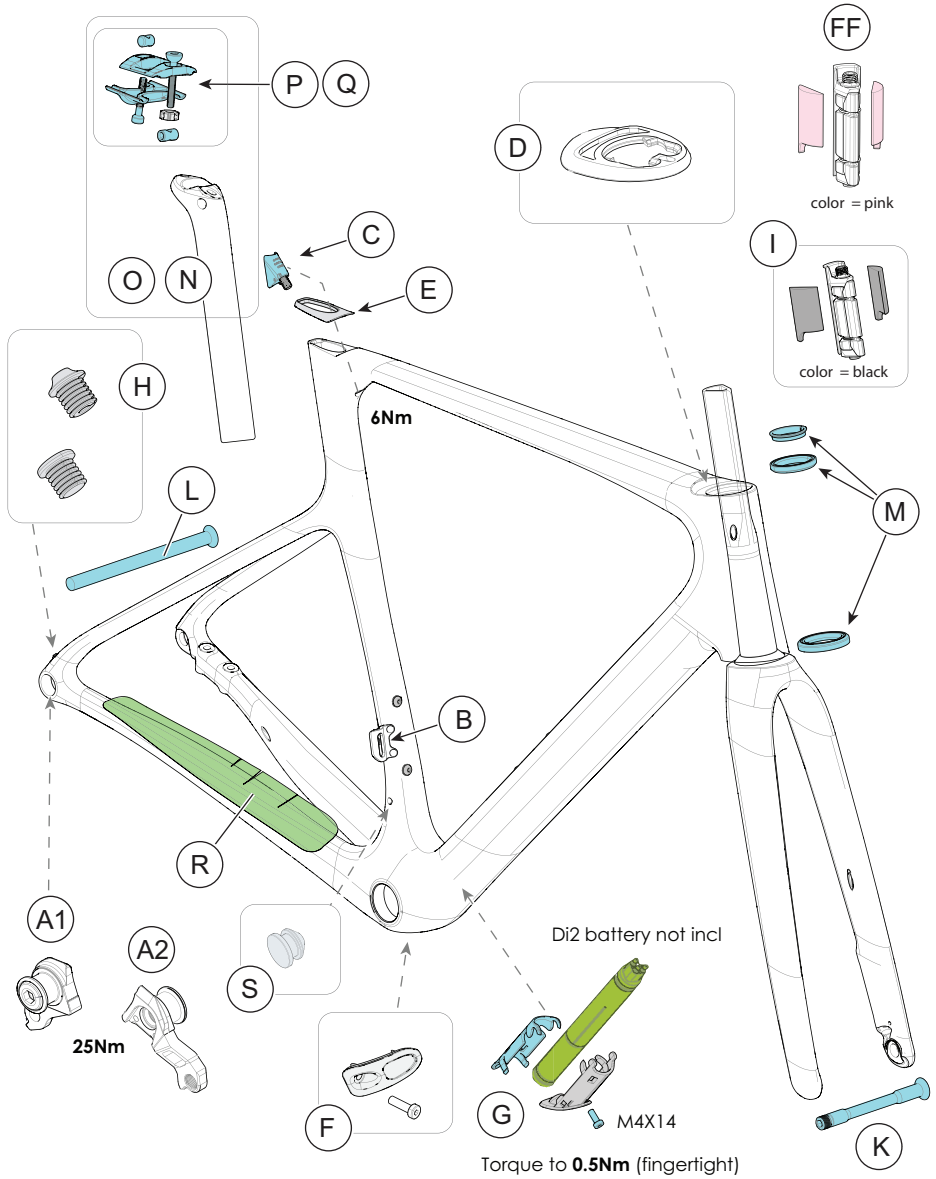

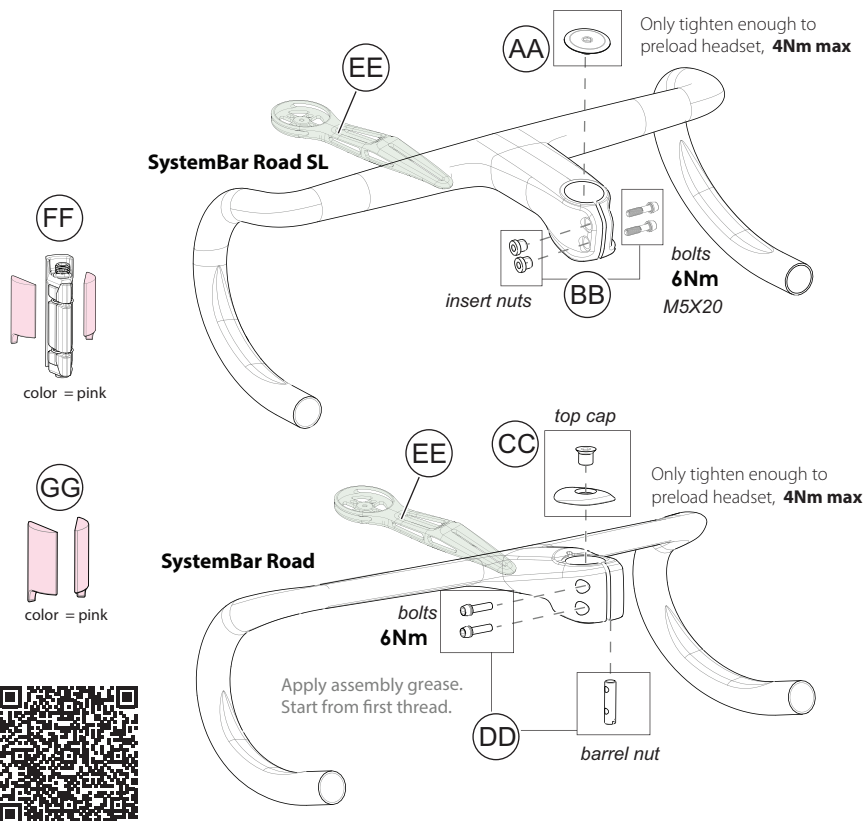









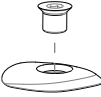

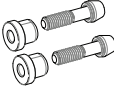
**▲WARNING:** Both handlebars - alternate tightening bolts in 1 Nm steps until both are tightened to 6 Nm.

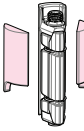
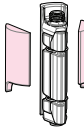
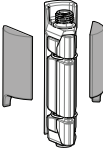
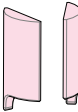
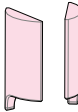
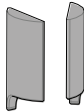
## SystemBar Kits

ID	Part Number	Description	SL	Road
AA	K21036	SystemBar SL Top Cap	X	
BB	K21046	SystemBar SL Bolts Clamp Hardware M5×20	X	
CC	K21016	SystemBar Aero Top Cap + Bolt		X
DD	K21026	SystemBar Clamp Hardware M5X20		X
EE	K18006	SystemBar Road SL Computer Mount	X	X
see	K18026	SL Mount Insert:Hammerhead Computer M3×6	X	X
page	K18036	SL Mount Insert:Garmin Computer M3×6	X	X
19	K18046	SL Mount Insert:Wahoo Computer M3×6	X	X
FF	K35063	SystemBar Delta Expander Plug	X	X
GG	K3508310	SystemBar Delta Filler Pieces L+R PNK	X	X

## SuperSix EVO 5 Delta Steerer Cockpit Configurations

Part	SystemBar SL	SystemBar Road	Conceal
<i>Top Cap</i>	K21036 Replaces round top cap in K35063 	K21016 Replaces round top cap in K35063 	K35042 
<i>Shroud</i>	n/a	n/a	K28142 
<i>Hardware</i>	K21046 	K21026 	K28082 6X 
<i>Expander ***</i>	K35063 	K35063 	K35051 
<i>Filler Pieces</i>	K3508310*  color = pink	K3508310*  color = pink	K3507310**  color = black
<i>Spacers</i>	K28062 	K28062 	K28062 
<i>Dust Cover</i>	K35006 	K35006 	K35006 

\* Also included with K35063 Expander

\*\* Also included with K35051 Expander

\*\*\* Base expander assembly is shared across all configurations. Filler Pieces and Top Cap decide compatibility







## **Cannondale Help Center**

Our online Help Center contains helpful resources to consult about our bikes.



<https://cannondale.zendesk.com/hc/en-us>

## **Bike Registration**

To register your bike:

Go to the Product Registration section of our website at [www.cannondale.com](http://www.cannondale.com)



[www.cannondale.com](http://www.cannondale.com)  
© Cycling Sports Group, Inc.  
SuperSix EVO OMS  
199469 Rev 0 (01/26)

**CANNONDALE USA**

Cycling Sports Group, Inc.  
1 Cannondale Way,  
Wilton CT, 06897, USA  
1-800-726-BIKE (2453)  
[www.cannondale.com](http://www.cannondale.com)

**CANNONDALE EUROPE**

Cycling Sports Group Europe B.V.  
Geeresteinselaan 57  
3931JB Woudenberg  
The Netherlands  
[service@cyclingsportsgroup.com](mailto:service@cyclingsportsgroup.com)